

RCM - Sprayer and Hawkeye® 2 Calibration and Operation Manual

016-0171-638 Rev. C

2/2022

E40980



DISCLAIMER

While every effort has been made to ensure the accuracy of this document, Raven Industries assumes no responsibility for omissions and errors. Nor is any liability assumed for damages resulting from the use of information contained herein.

Raven Industries shall not be responsible or liable for incidental or consequential damages or a loss of anticipated benefits or profits, work stoppage or loss, or impairment of data arising out of the use, or inability to use, this system or any of its components. Raven Industries shall not be held responsible for any modifications or repairs made outside our facilities, nor damages resulting from inadequate maintenance of this system.

As with all wireless and satellite signals, several factors may affect the availability and accuracy of wireless and satellite navigation and correction services (e.g. GPS, GNSS, SBAS, etc.). Therefore, Raven Industries cannot guarantee the accuracy, integrity, continuity, or availability of these services and cannot guarantee the ability to use Raven systems, or products used as components of systems, which rely upon the reception of these signals or availability of these services. Raven Industries accepts no responsibility for the use of any of these signals or services for other than the stated purpose.

Calibration Reference Sheet	v
Unit Definitions and Conversions	vii
Unit of Measure Definitions	vii
Unit of Measure Conversions	vii
Chapter 1 Important Information.....	1
Safety	1
Agricultural Chemical Safety	2
Electrical safety	2
Recommendations and Best Practices	3
Hose Routing	3
Harness Routing	3
Compliance	4
Chapter 2 Introduction.....	5
RCM - Sprayer Features	5
Operation Modes	5
Operation Mode Features	8
Care and Use	9
Updates	10
Chapter 3 System Calibration.....	11
Initial Start Up and Calibration Wizard	11
Transfer Universal Terminals	12
Unlocks	12
Calibration Wizard	12
Functional Inspection	19
System Function	19
Turn Compensation Feature	20
Chapter 4 System Setup.....	21
Tools Menu Overview	21
Applicator Setup Tab	22
Profile and Machine Type	22
Section Setup Summary	22
Fence Row Settings	23
Precision Farming Setup Wizard	24
NCV Control Mode (Systems with Hawkeye® 2)	24
Section Control Mode Display	25
Select Tip	25
Test Speed and Turn Compensation	26
System Settings Tab	27
Control Valve Settings and Tuning	27
Rate Sensor Setup	29
Tank Fill Settings	31
Display Setup Menu	32
Pressure Setup	35

TABLE OF CONTENTS

NCV Information	36
User Settings	37
Pump RPM Calibration	41
Alarm Settings Tab	41
Off Pressure Alarm	41
Off Rate Alarm	41
NCV Efficiency % Alarm	42
Unexpected System Flow Change	42
Stuck Poppet	42
Rates Setup Tab	43
Preset Rate Values	43
Preset Pressures	43
Rate Selection	43
Display Smoothing	43
Ratio Rate	44
Feature Unlocks Tab	44
Enter Activation Keys	44
Chapter 5 Precision Farming Setup	45
Chapter 6 Operation	49
Operation Checklist	49
Universal Terminal Definitions	50
UT Working Set menu	50
Quick Access Softkeys	51
RCM - Sprayer Home Page Features	52
Readouts	54
RCM - Sprayer Lower Home Screen	54
Automated Boom Prime	57
Chapter 7 Totals	59
Using Totals	59
Reset a Register	60
Chapter 8 Diagnostics	61
System Diagnostics	61
System Information	61
Tests	62
Diagnostic Trouble Codes (DTCs)	67
System Summary	82
NCV Diagnostics	83
Individual NCV Diagnostics	84
NCV Updates	85
Chapter 9 Troubleshooting	87
RCM - Sprayer Status LED	87
NCV Technical Specifications	89

Hawkeye® 2 Nozzle Control Valve Status	89
NCV Offline troubleshooting	91
NCV ALARMS	91
NCV Diagnostics	92
Other Related Errors	92
Cable Troubleshooting	95
Troubleshooting NCV Cable Connections	95
Troubleshooting 19-Pin Boom Cable Connections	96
Troubleshooting Terminator Connections Near the RCM	96
Troubleshooting Flow Meter Cables	97
General Troubleshooting	98
Appendix A Avoiding Skips with Hawkeye® 2 Nozzle Control System	101
Overview	101
Recommendations for Hawkeye® 2 Nozzle Control Operation	101
Causes of Skips using Hawkeye® 2 Nozzle Control	103
Tip Selection and Application Speed Guide	105
Droplet Sizing	105
Application Speed Guide	107
Appendix B Calibration Values.....	113
Section Widths	113
Target Rate Calibration	113
Product Calibration Settings	114
Flow meter Re-Calibration	114
Specifications Based on Water	115
Appendix C Maintenance Schedule and Replacement Parts	117
System Maintenance	117
Nozzle Control Valve Maintenance Procedure	122
Hawkeye® 2 Nozzle Control Valve Assembly Procedure	124
System Testing	125
Testing for Leaks	125
Flow Meter Maintenance	125
Recalibrating the Flow Meter	126
Appendix D Cable and Connector Maintenance	127
Power and RCM - Sprayer ECU Harness Maintenance	127
Boom Harness Connector Maintenance	127
Appendix E Storage and Start-Up Checklist.....	131
System Storage and Start-Up Checklist	131
Preseason Cleaning and Flushing	131
Start-Up Inspection	131
Functional Inspection	132
Winterizing and Storing the System	134

Appendix F Remote Control and Diagnostics **135**
Wireless Section Control Remote Operation **135**

CALIBRATION REFERENCE SHEET

Record settings and calibration values used when programming the system in the fields below and keep this sheet for future reference.

GENERAL IMPLEMENT INFORMATION

UNITS	US (Acres)	SI (Hectares)	Tip Spacing		Section Offset	
Speed Cal			Tip Size		Boom Width	
Total NCVs		Left NCVs (if present)				

Section Cals						
	Width	Signal Driver	Switch Number	Auto-Operation Times	On Time	Off Time
Section Number	1.					
	2.					
	3.					
	4.					
	5.					
	6.					
	7.					
	8.					
	9.					
	10.					
	11.					
	12.					
	13.					
	14.					
	15.					
	16.					
	Width	Switch Number	Linked to Outer?	Mapped as Sections?		
Left Fence Row						
Right Fence Row						

TANK FILL SETTINGS

Tank Capacity		Low Tank Level	
Product Type		Max Tank Fill PWM	

CONTROL VALVE SETUP

Control Valve Type		Valve Response Rate		PWM High Limit %	
Control Deadband		Minimum NCV PWM		PWM Low Limit %	
NCV Response Sensitivity		PWM Coil Frequency		Standby Pump PWM %	
PWM High Limit		PWM Low Limit		PWM High Side Drive	
Standby Pump PWM		PWM High Side Drive			

RATE SENSOR SETUP

Flow Meter Calibration		Flow Meter Pulse/Units	
Flow Meter Low Limit		Tank Capacity	
Tank Fill/Level Sensor		Tank Fill FlowMeter Calibration Units	

PUMP RPM SETTINGS

Pump RPM Calibration		Pump RPM Minimum	
Pump RPM Maximum			

PRESSURE SETTINGS

Minimum Pressure		Maximum Pressure	
Boom Pressure Range		Sparge Pressure Range	

PRECISION FARMING

Product Delay		On Time	
Rear Implement		Left of	

UNIT DEFINITIONS AND CONVERSIONS

UNIT OF MEASURE DEFINITIONS

Abbreviation	Definition	Abbreviation	Definition
GPM	Gallons per Minute	cm	Centimeters
L/min	Liters per Minute	dm	Decimeters
dL/min	Deciliters per Minute	m	Meter
psi	Pounds per Square Inch	mph	Miles per Hour
kPa	Kilopascal	km	Kilometers
GPA	Gallons per Acre	kph	Kilometers per Hour
L/ha	Liters per Hectare	[]	Unit Conversions
mL/ha	Milliliters per Hectare	lb/acre	Pounds per Acre
GPK	Gallons per 1,000 Square Feet	kg/ha	Kilograms per Hectare
mm	Millimeters		

UNIT OF MEASURE CONVERSIONS

To convert the meter cal value into the selected unit of measure, divide the original number printed on the flow meter label by the desired conversion value.

Fluid Ounces Conversion Formula	Liters Conversion Formula	Pounds Conversion Formula
$\frac{\text{Original Meter Cal}}{128}$	$\frac{\text{Original Meter Cal}}{3.785}$	$\frac{\text{Original Meter Cal}}{\text{Weight of One Gallon of Product}}$

Liquid	Area
<ul style="list-style-type: none"> • 1 U.S. gallon = 128 fluid ounces • 1 U.S. gallon = 3.785 liters • 1 U.S. gallon = 0.83267 imperial gallons • 1 U.S. gallon = 8.34 pounds (water) • 1 U.S. gallon = 10.67 pounds (28% N) • 1 U.S. gallon = 11.06 pounds (32% N) • 1 U.S. gallon = 11.65 pounds (10-34-0) 	<ul style="list-style-type: none"> • 1 square meter = 10.764 square feet • 1 hectare = 2.471 acres or 10,000 square meters • 1 acre = 0.405 hectares or 43,560 square feet • 1 square mile = 640 acres or 258.9 hectares

Length	Pressure
<ul style="list-style-type: none">• 1 millimeter (mm) = 0.039 inches• 1 centimeter (cm) = 0.393 inches• 1 meter (m) = 3.281 feet• 1 kilometer (km) = 0.621 miles• 1 inch = 25.4 mm or 2.54 cm• 1 mile = 1.609 km	<ul style="list-style-type: none">• 1 psi = 6.89 kPa or 0.07 bar or 51.52 mmHg• 1 kPa = 0.15 psi or 0.01 bar or 7.5 mmHg• 1 bar = 14.5 psi or 100 kPa or 0.99 atm• 1 inHg = 25.3 mmHg• 1 mmHg = 0.04 inHg

SAFETY

NOTICE

Follow the operation and safety instructions included with the implement and/or controller and read this manual carefully before installing or operating this Raven system.

- Follow all safety information presented within this manual. Review implement operation with your local dealer.
- Contact a local Raven dealer for assistance with any portion of the installation, service, or operation of Raven equipment.
- Follow all safety labels affixed to system components. Be sure to keep safety labels in good condition and replace any missing or damaged labels. Contact a local Raven dealer to obtain replacements for safety labels.

Observe the following safety measures when operating the implement after installing this Raven system:

- Do not operate this Raven system or any agricultural equipment while under the influence of alcohol or an illegal substance.
- Be alert and aware of surroundings and remain in the operator seat at all times when operating this Raven system.
 - Do not operate the implement on any public road with this Raven system enabled.
 - Disable this Raven system before exiting the operator seat.
 - Determine and remain a safe working distance from obstacles and bystanders. The operator is responsible for disabling the system when a safe working distance has diminished.
 - Disable this Raven system prior to starting any maintenance work on the implement or components of this Raven system.
- Do not attempt to modify or lengthen any of the system control cables. Extension cables are available from a local Raven dealer.

WARNING

AGRICULTURAL CHEMICAL SAFETY

Follow all federal, state, and local regulations regarding the handling, use, and disposal of agricultural chemicals, products, and containers. Triple-rinse and puncture or crush empty containers before properly disposing of them. Contact a local environmental agency or recycling center for additional information.

- Always follow safety labels and instructions provided by the chemical manufacturer or supplier.
- Always wear appropriate personal protective equipment as recommended by the chemical and/or equipment manufacturer.
- When storing unused agricultural chemicals:
 - Store agricultural chemicals in the original container and do not transfer chemicals to unmarked containers or containers used for food or drink.
 - Store chemicals in a secure, locked area away from human and livestock food.
 - Keep children away from chemical storage areas.
- Fill, flush, calibrate, and decontaminate chemical application systems in an area where runoff will not reach ponds, lakes, streams, livestock areas, gardens, or populated areas.
- Follow all label instructions for chemical mixing, handling, and disposal.
- Avoid direct contact with agricultural chemicals or inhaling chemical dust or spray particulate. Seek immediate medical attention if symptoms of illness occur during, or soon after, use of agricultural chemicals or products.
- After handling or applying agricultural chemicals:
 - Thoroughly wash hands and face after using agricultural chemicals and before eating, drinking, or using the restroom.
 - Thoroughly flush or rinse equipment used to mix, transfer, or apply chemicals with water after use or before servicing any component of the application system.

CAUTION

ELECTRICAL SAFETY

- Always verify that power leads are connected to the correct polarity as marked. Reversing the power leads could cause severe damage to the Raven system or other components.
- To prevent personal injury or fire, replace defective or blown fuses with only fuses of the same type and amperage.
- Do not connect the power leads to the battery until all system components are mounted and all electrical connections are completed.
- Always start the machine before initializing this Raven system to prevent power surges or peak voltage.
- To avoid tripping and entanglement hazards, route cables and harnesses away from walkways, steps, grab bars, and other areas used by the operator or service personnel when operating or servicing the equipment.

RECOMMENDATIONS AND BEST PRACTICES

HOSE ROUTING

The word “hose” is used to describe any flexible, fluid carrying components. Use the following guidelines and recommendations when connecting and routing hoses while installing or maintaining this Raven system:

- Leave protective caps/covers over hose ends until connecting the end into the hydraulic system to help prevent contaminants from entering the system. Cap or cover any hose ends disconnected for service or maintenance.
- Follow existing hose runs already routed on the implement as much as possible. Proper hose routing should:
 - Secure hoses and prevent hoses from hanging below the implement.
 - Provide sufficient clearance from moving components and operational zones around shafts; universal joints and suspension components; pulleys, gears, belts, and chains; moving linkages, cylinders, articulation joints, etc.
 - Protect hoses from field debris and surrounding hazards (e.g. tree limbs, fence posts, crop stubble, dirt clumps or rocks that may fall or be thrown by the implement).
 - Protect hoses from sharp bends, twisting, or flexing over short distances and normal implement operation.
 - Ensure sufficient length for free movement of the implement during normal operation and prevent pulling, pinching, catching, or rubbing, especially in articulation and pivot points. Clamp hoses securely to force controlled movement of the hose.
 - Avoid abrasive surfaces and sharp edges such as sheared or flame cut corners, fastener threads or cap screw heads, hose clamp ends, etc.
 - Avoid areas where the operator or service personnel might step or use as a grab bar.
- Do not connect, affix, or allow hoses to come into contact with components with high vibration forces, hot surfaces, or components carrying hot fluids beyond the temperature rating of hose components.
 - Hoses should be protected or shielded if routing requires the hose to be exposed to conditions beyond hose component specifications.
- Avoid routing hoses in areas where damage may occur due to build up of material (e.g. dirt, mud, snow, ice, etc.).

HARNESS ROUTING

The word “harness” is used to describe any electrical cables and leads, both bundled and unbundled. Use the following guidelines and recommendations when connecting and routing harnesses while installing or maintaining this Raven system:

- Leave protective caps/covers over harness connectors until needed to avoid dirt and moisture from contaminating electrical circuits. Cap or cover any harness connectors disconnected for service or maintenance.
- Secure the harness to the frame or solid structural members at least every 12 in [30 cm].
- Follow existing harness runs already routed on the implement as much as possible. Proper harness routing should:
 - Secure harnessing and prevent the harness from hanging below the implement.
 - Provide sufficient clearance from moving components and operational zones around shafts; universal joints and suspension components; pulleys, gears, belts, and chains; moving linkages, cylinders, articulation joints, etc.
 - Protect harnessing from field debris and surrounding hazards (e.g. tree limbs, fence posts, crop stubble, dirt clumps or rocks that may fall or be thrown by the implement).

- Protect harnessing from sharp bends, twisting, or flexing over short distances and normal implement operation.
- Connectors and splices should not be located at bending points or in harness sections that move.
- Ensure sufficient length for free movement of the implement during normal operation and prevent pulling, pinching, catching, or rubbing, especially in articulation and pivot points. Clamp harnessing securely to force controlled movement of the harness.
- Avoid abrasive surfaces and sharp edges such as sheared or flame cut corners, fastener threads or cap screw heads, hose clamp ends, etc.
- Do not connect, affix, or allow harnessing to come into contact with components with high vibration forces, hot surfaces, or components carrying hot fluids beyond the temperature rating of harness components.
 - Harnessing should be protected or shielded if routing requires the hose to be exposed to conditions beyond harnessing component specifications.
- Avoid routing harnesses in areas where damage may occur due to build up of material (e.g. dirt, mud, snow, ice, etc.).
- Avoid routing harnesses in areas where the operator or service personnel might step or use as a grab bar.

IMPORTANT: Avoid applying direct spray or pressure washing of electrical components and connections. High pressure streams and sprays can penetrate seals, cause corrosion, or otherwise damage electrical components.

When performing maintenance:

- Inspect electrical components and connectors for corrosion, damaged pins or housings, etc. Clean and resolve any corrosion issues or replace components or harnessing as necessary.
- Ensure connectors are kept clean and dry. Apply Corrosion X HD to connector mating surfaces and contacts exposed to moisture, dirt, debris, and other contaminants. Repair or replace harnessing as necessary.
- Clean electrical components with pressurized air, aerosol electrical cleaning agent, or low pressure rinse.
- Remove visible surface water from electrical components and connections using pressurized air or an aerosol cleaning agent. Allow components to dry thoroughly before applying corrosion inhibitor and reconnecting cables.

COMPLIANCE

The BLUETOOTH® word mark and logos are registered trademarks owned by Bluetooth SIG, Inc. and any use of such marks by Raven Industries, Inc. is under license. Other trademarks and trade names are those of their respective owners.

The Raven Rate Control Module (RCM) - Sprayer system is designed to provide rate control via an ISOBUS universal terminal (UT).

Adding the Hawkeye® 2 nozzle control system to the RCM - Sprayer allows the machine operator to monitor and control pressure independently from the application rate without additional displays, controllers, or consoles.

This document provides information regarding the following aspects of the RCM - Sprayer and Hawkeye® 2 control systems:

- Initial Setup and Navigation
- Calibration
- System Operation
- Updating Components

NOTE: Prior to using the control features with any UT display, the RCM - Sprayer and Hawkeye® 2 Electronic Control Unit (ECU) must be calibrated for the control system. Refer to Chapter 3, *System Calibration*, for assistance with completing the initial calibration wizard.

This manual assumes that the required control hardware is already installed on supported equipment and is properly connected. Refer to the *Updates* section on page 10 for installation manual resources or contact a local Raven dealer for additional information on supported equipment configurations.

RCM - SPRAYER FEATURES

OPERATION MODES

The RCM - Sprayer with Hawkeye® 2 control system can be configured in several different modes to fit the application.

Proceed to the next page to view Table 1, "Operation Modes and Compatible Features," on page 6.

TABLE 1. Operation Modes and Compatible Features

		Modes of Operation					Tiered Nozzle
		Conventional /Bypass	On/ Off	Standard	Variable Pressure (VP)	High Flow	
Compatible Features	Nozzle Used	Bypass	NCV	NCV	NCV	NCV + Bypass	NCV + (Electronic) Bypass
	Recommended NCV Tip Size ¹	NA	02-15	02-15	02-15	02-15	02-15
	Speed Range	NA	NA	Good	Best	Good	Good
	Turn Compensation	NA	NA	Good	Best	Good	Good
	Pressure Control ²	Range	Range	Target	Range	Target	Target
	Coverage	Best	Best	Good	Better	Good	Good
	Direct Injection ³	Yes	Yes	Yes	Yes	Yes	Yes
	Wireless Diagnostics	Yes	Yes	Yes	Yes	Yes	Yes
	Automated Priming ⁴	Yes	Yes	Yes	Yes	Yes	Yes
	Product Recirculation ⁵	No	Yes	Yes	Yes	No	Yes
	Droplet Indicator	Yes	Yes	Yes	Yes	No	No
	Air Induction Tip Compatibility ⁶	Yes	Yes	No	No	No	No
	Operating Frequency	NA	NA	10 Hz	10 Hz	10 Hz	10 Hz
	Nozzle Flow Offsets ⁷	No	No	Yes	Yes	Yes	Yes
	Hawkeye HD Individual Nozzle Control and Manual Override NCV Off ⁸	No	Yes	Yes	Yes	No	Yes
Virtual Sections ⁹	No	Yes	Yes	Yes	No	No	

1. Use Bypass, High Flow, or Tiered Nozzle modes if calculated target flow requirements per tip exceed 1.4 gpm [5.3 l/min].
2. "Target" indicates the user sets a target pressure. "Range" indicates the user sets a min/max pressure range.
3. Maximum of 5 ICD injection pumps may be connected with the Hawkeye® 2 control system.

4. Automatically primes the main product only.
5. Recirculates the main product only. Requires a feature unlock.
6. Unless otherwise stated by the tip manufacturer, air induction tips are not recommended when using PWM nozzle control.
7. There exists two user-set profiles of four nozzles per profile. Profiles may be run simultaneously.
8. Requires individual nozzle control unlock for operation. Can only be used in the presented modes of NCV operation.
9. Up to 16 virtual sections will be available if individual nozzle control is not unlocked, or if the field computer does not support over 16 sections.

Bypass (Conventional) Mode. The RCM - Sprayer with Hawkeye® 2 mode will control to a target flow, but the nozzle control valves on the system are disabled. A secondary flow outlet must be made available at each tip.

NOTE: If NCVs are not detected, the RCM - Sprayer system will automatically configure in Bypass mode. Bypass mode may also be selected to revert a system with Hawkeye® 2 NCVs to conventional spray control.

Only select bypass mode if the nozzle bodies on the implement are set to bypass the Hawkeye® 2 NCVs during operation.

On/Off Mode. The RCM - Sprayer with Hawkeye® 2 System will hold the NCVs 100% open during application or fully closed when not applying. This mode can be used with air induction tips and stream bars.

Standard Mode. The RCM - Sprayer with Hawkeye® 2 mode will control to a target flow rate and maintain a constant target pressure for maintaining droplet size.

Variable Pressure (VP) Mode. This RCM - Sprayer with Hawkeye® 2 mode will control to a target flow rate and target NCV duty cycle by varying the pressure range. This is useful for scenarios where having a wide speed and coverage range while maintaining a pressure range is a priority such as liquid fertilizer application or where droplet size can be maintained over a wide pressure range.

High Flow Mode. This RCM - Sprayer with Hawkeye® 2 mode allows both a conventional nozzle and a Hawkeye® 2 NCV to run simultaneously to achieve higher flow rates while maintaining a constant target pressure.

Tiered Nozzle Mode. Tiered Nozzle mode allows both Hawkeye® 2 NCVs (tier A) and individually electronically controlled conventional nozzles (tier B) to run sequentially and simultaneously to achieve wider range of flow rates.

The NCV (Tier A) will control at low flow rates and up to the NCV flow limit. Then the conventional nozzle (Tier A+B) will turn on to add to the control range while the NCV continues to regulate flow by varying duty cycle up to the maximum flow of both Tiers at a set pressure.

NOTE: The Tip selection impacts the transition between Tiers. For smooth operation, the NCV tip should be larger than the conventional tip.

NOTE: The Tiered Nozzle mode requires electronically actuated conventional individual nozzles (solenoid, ball valve, cabling to control the conventional nozzles, etc.) in addition to the Hawkeye® 2 NCVs to operate in this mode.

OPERATION MODE FEATURES

Turn Compensation. Turn compensation helps ensure an even flow rate while applying around curves and corners, even when operating with the largest of application equipment sizes on the market. Turn compensation automatically reduces or stops the flow rate of NCVs toward the inside of the curve, while increasing the flow rate at the outside, to help ensure an even, efficient application to address crop conditions, minimize crop damage, and improve yields. Refer to the *Enable Turn Compensation* section on page 38 for additional assistance with enabling the Turn Compensation feature.

Pressure Nozzle Control. The RCM - Sprayer with Hawkeye® 2 control system provides the same spray pattern and coverage as conventional spray systems. Pressure-based nozzle control allows the operator to maintain the same target pressure and operate over a larger application speed or flow range while maintaining droplet size. This may help manage spray drift and allow the equipment to operate in higher winds. Pressure-based control also allows better rate control at lower target flow rates than the flow meter can detect.

Direct Injection. Direct injection allows efficient and accurate application of liquid chemicals applied from an injection module. A separate injection module or tank eliminates mixing chemicals in the main tank, reduces chemical waste, and simplifies equipment care and maintenance.

Connect up to five Sidekick Pro™ ICD injection systems to the Viper 4 and ISOBUS to control the whole system through the Hawkeye® 2 user interface screens on the universal terminal. Select a high flow injection system to control a wide range of chemical flow rates from 5 - 200 oz/min. Select a low flow injection system to provide chemical flow rates from 1 - 40 oz/min. Refer to the Sidekick Pro™ ICD Calibration and Operation Manual for additional information on setting up the direct injection system.

Wireless Diagnostic Control. Wireless diagnostic control allows the user to control the system and perform diagnostics by using a wireless remote. The user can turn on and off boom sections, or turn the pump on or off, for troubleshooting or demonstration purposes without having to leave the cab.

NOTE: Refer to Appendix F, *Remote Control and Diagnostics*, for additional assistance with the wireless remote.

Automated Boom Priming. This feature streamlines the conventional boom priming process, where product is sprayed out of the boom until consistent product application is achieved at all spray tips. Whether removing air, chemical, or rinse water, the Automated Boom Priming feature makes sure the priming process is consistent. Boom Priming requires no additional cabling or plumbing, may be used in any mode of operation, and allows the user to adjust the Section Auto-Operation times to fine-tune the priming process.

Boom Recirculation. Boom Recirculation allows the user to circulate product from the tank, to the boom, and back. A machine operator may prime the spray system, re-suspend chemicals that may have separated within the boom, and minimize chemical deposit buildup, all without dispensing product from the boom spray tips.

Boom recirculation may be enabled and disabled automatically or manually from the UT when not spraying. Users can adjust the Section Auto-Operation times to perfect the amount of circulation happening per section. Enabling this feature requires NCV installation, system plumbing, and wiring changes to accommodate additional components, and cannot be active when direct injection is in use.

Flow Offsets. The flow offset feature allows the operator to adjust the flow rate of a set of NCVs anywhere on the boom by $\pm 50\%$ from the rest of the boom to maintain optimal coverage.

The flow offset may be activated on up to two configured NCV Flow Offset profiles simultaneously. Two operator defined NCV Flow Offset profiles are available, and each profile may contain up to four NCV assignees.

Virtual Sections. This feature allows the system to automatically divide nozzles on the boom in up to 16 virtual sections.

Hawkeye® 2 HD Individual Nozzle Control. Unlock the Hawkeye® 2 HD Individual Nozzle control feature for the finest product application resolution and accuracy. This mode turns each NCV into an individual boom section and offers maximum product savings. Contact a local Raven dealer for more information.

NCV Override Off. If HD Individual Nozzle Control is unlocked, the user can override any number of individual NCVs off while spraying. This can be done with or without showing coverage for that area. Actual application rates are automatically adjusted to ensure remaining NCVs are applying correctly.

NOTE: Any additional direct injection products on the system would need to be independently primed.

CARE AND USE

Always follow equipment manufacturer's recommended maintenance procedures for storing equipment. Perform the following maintenance procedures before storing equipment with the control system:

1. Empty product from the chemical supply tank and flush the application system with water or an approved tank cleaner following the machine manufacturer's recommended procedures.

NOTE: A tank cleaner compatible with Viton™ seal materials is recommended for use with the Hawkeye® 2 NCVs.

2. Remove hardened chemical residues or build up by flushing the system with soap and water.
3. Prime the system plumbing with a 50% water and automotive antifreeze mixture to prevent freezing of NCV components. Freezing can result in damage to the system and other plumbing components on the system.

Refer to Appendix C, *Maintenance Schedule and Replacement Parts*, for additional assistance with maintaining the Hawkeye® 2 nozzle control valves.

UPDATES

Updates for Raven manuals as well as software updates for Raven consoles, ECUs, and Hawkeye® 2 NCVs are available at the Applied Technology Division web site:

<https://portal.ravenprecision.com/>

NOTE: It may be necessary to reset or recalibrate the system after the update is complete. Prior to performing a software update, record all settings in the *Calibration Reference Sheet* section on page v.

Each RCM - Sprayer update may include a new NCV software package which will update NCVs connected to the system. If an NCV is replaced, the replacement NCV may cause a system notification that NCV software is mismatched or out-of-date and requires an update. Individual NCVs may be updated via the same process in the RCM - Sprayer.

The Raven Service Tool (P/N 117-0171-464) and a laptop PC (Windows 7 or newer), or a Raven UT, are required to update the RCM - Sprayer ECU. Refer to the Raven Service Tool Operation Manual (P/N 016-5030-022) for additional assistance with updating the RCM - Sprayer.

Refer to *NCV Updates* section on page 85, for additional assistance with performing device updates.

NOTE: Sign up for e-mail alerts to receive notifications when updates for your Raven products are available on the Raven web site.

At Raven Industries, we strive to make your experience with our products as rewarding as possible. One way to improve this experience is to provide us with feedback on this manual.

Your feedback will help shape the future of our product documentation and the overall service we provide. We appreciate the opportunity to see ourselves as our customers see us and are eager to gather ideas on how we have been helping or how we can do better.

To serve you best, please send an email with the following information to

techwriting@ravenind.com

- RCM - Sprayer and Hawkeye® 2 Calibration and Operation Manual
- 016-0171-638 Rev. C
- Any comments or feedback (include chapter or page numbers if applicable).
- Let us know how long have you been using this or other Raven products.

We will not share your email or any information you provide with anyone else. Your feedback is valued and extremely important to us.

Thank you for your time.

INITIAL START UP AND CALIBRATION WIZARD

The calibration wizard must be completed the first time that the system is powered up on the ISOBUS network or if the default system settings are reset. The calibration wizard allows the operator to quickly configure the Rate Control Module (RCM) - Sprayer ECU and Hawkeye® 2 NCVs if detected.

Review the following sections for assistance with completing the calibration wizard for the Hawkeye® 2 control system.

NOTE: Refer to the UT Operation Manual for other necessary setup or calibration required before operating the RCM - Sprayer control system or features.

FIGURE 1. Home Page (Basic Display Mode)

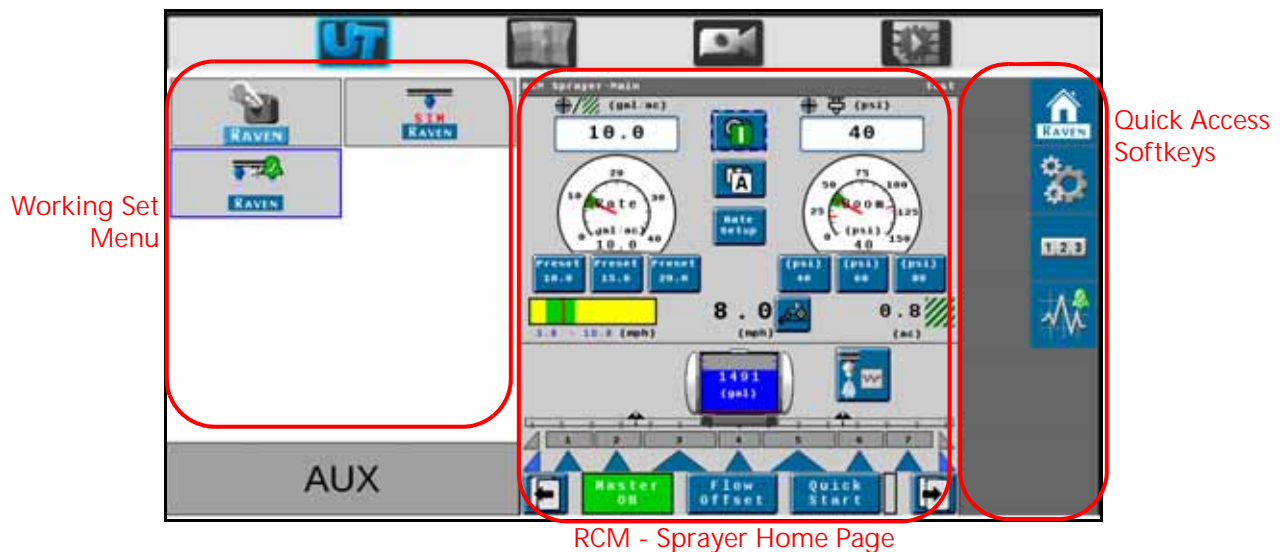

TRANSFER UNIVERSAL TERMINALS

The Transfer UT softkey will be displayed if more than one UT is detected on the ISOBUS. Use this button to switch the RCM - Sprayer working set menu to an alternate UT at any time.



Transfer UT

If the working set is not available on the desired UT, check the other displays and use the Transfer UT softkey to transfer the RCM - Sprayer working set.

By default, the working set will load to the first UT detected by the ISOBUS. When using the Transfer UT softkey, the working set will automatically load to the last UT selected unless the system requires calibration or the last UT cannot be detected within two minutes.



RCM - Sprayer Menu

UNLOCKS

NOTE: If features are unlocked after the initial calibration wizard is completed, a new profile must be created and the calibration wizard must be completed before the feature will be available.



Unlocks

An Unlocks softkey is displayed during the calibration wizard and allows the operator to activate and enable features on the system prior to completing the wizard. This will allow the operator to properly calibrate all features available on the system (e.g. Hawkeye HD Individual Nozzle Control, boom recirculation, etc.) before creating and completing a profile.

Review the *Feature Unlocks Tab* section on page 44 for assistance with entering unlock codes.

CALIBRATION WIZARD

The following steps may help with completing the initial setup of the RCM - Sprayer control system:

1. Turn the UT power on and allow the display to initiate the ISOBUS system.

NOTE: If properly connected and powered, the UT will automatically detect the Raven RCM - Sprayer ECU.

If the RCM - Sprayer ECU is not detected by the display terminal, troubleshoot the ECU and restart the system. Refer to Chapter 9, *Troubleshooting*, for assistance with connection issues or contact a local Raven dealer for additional troubleshooting assistance.

2. Once the RCM - Sprayer ECU is detected, the RCM - Sprayer Menu button will display in the UT Menu.
3. Touch the Menu button to access the control system user interface.
4. The first time that the system is started on the UT, or if a new profile is created, the calibration wizard prompt will be displayed.

PROFILE NAME AND MACHINE TYPE

1. Touch the Profile Name field and enter a name for the machine or equipment configuration being set up.
2. Touch the Machine Type drop-down field and select the option that best matches type of machine or equipment to be configured.
3. Select the Next button to continue to the NCV Setup page.

SYSTEMS WITH SIDEKICK PRO ICD INJECTION PUMPS

1. Locate the Sidekick Pro ICD ECU serial number. The serial number is typically located on the front or top of the direct injection pump.
2. Assign the desired Sidekick Pro ICD ECU to the desired product channel ECU number.

NOTE: The RCM-Sprayer ECU is factory configured as ECU number 1 and cannot be changed.

FIGURE 2. Injection Wizard Serial Number Assignment

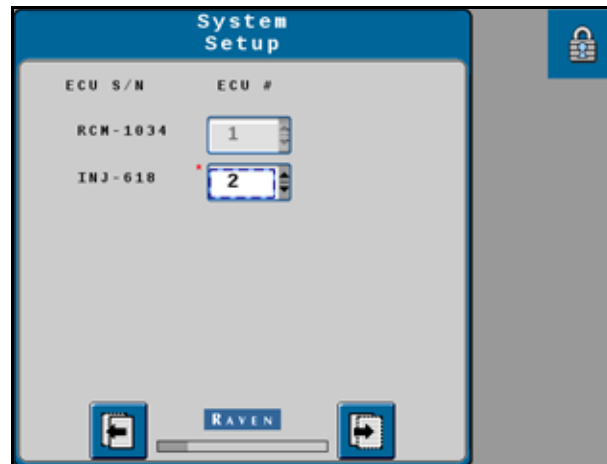

3. Press the Next softkey.

TIP SETUP, SPACING, AND TIP SIZE

When setting up an RCM - Sprayer system without Hawkeye® 2 NCVs, or if the Skip NCV Setup option is selected:

1. Enter the "Bypass Tip Spacing" and "Bypass Tip Size."

NOTE: If no spray tips are installed, or if the installed tip size is not available in the drop down menu, select NA as the tip size.

When setting up a Hawkeye® 2 NCV control system:

1. Verify that the actual number of Hawkeye® 2 NCVs on the system matches the value shown in the Total NCVs field detected by the ECU.
2. Verify the actual number of NCVs connected to the left boom (center of the boom to the tip of the left boom) circuit matches the value shown in the Left NCV Count field detected by the ECU.

NOTE: Touch the Redetect NCVs button to allow the system to detect NCVs connected to the nozzle bus.

If the total number of NCVs, or the left NCV count, displayed does not match the actual number of nozzle control valves connected to the system, touch the Redetect NCVs button to allow the system to redetect NCVs connected to the nozzle bus. Refer to Chapter 9, *Troubleshooting*, for assistance with the Hawkeye® 2 nozzle control valve circuit.

To bypass nozzle control valve configuration and operate the system without the Hawkeye® 2 NCVs, press the Skip NCV Setup button. If Nozzle Control Valves are installed on the machine, the NCVs will remain closed and must be manually bypassed at the boom by opening a secondary flow outlet or removed from the machine to apply product. The system will then operate as a conventional sprayer with the RCM - Sprayer ECU.

3. Select the NCV Spacing field and enter the distance between nozzle bodies in the units displayed. A nozzle body spacing value must be entered to continue with the calibration.
4. Select the NCV Tip Size field and select the orifice size of the tips currently installed on the nozzle bodies.
 - NCV is the tip connected to the Hawkeye® 2 NCV.

NOTE: If no tips are installed, or the installed tip size is not available in the drop down menu, select NA as the Tip Size.

5. Select the Next button to proceed to the NCV Indexing prompt.

AUTOMATIC NCV INDEXING

The automatic NCV indexing process allows the Hawkeye® 2 system to automatically configure the location of each nozzle control valve on the left and right boom circuits and may detect issues with system connection or NCV setup.

1. The system will begin indexing Hawkeye® 2 NCVs from the center of the implement boom and move out to the end of the left boom. The indexing process automatically repeats for the right boom circuit, starting from the center and working toward the end of the boom. If an error is detected on either the left or right boom circuits, the RCM - Sprayer ECU will halt the indexing process and prompt the machine operator to correct the error before continuing with the calibration wizard. If an error occurs, troubleshoot the issue and press retry.
2. Select the Next button to continue.

SECTIONS AND FENCE ROW SETUP

Set up the number of sections and fence rows on the application equipment:

1. If available, select the Number of Sections field and enter the number of section on/off valves available for controlling product application across the boom width.
2. Enable the fence row option if fence row valves are controlled by the system. Select one of the following options for fence row control from the drop-down menu:

None. No fence rows available or will be controlled by the Hawkeye® 2 system.

Fence Valve. Select when the sprayer is equipped to use a ball or solenoid to project spray beyond the working width of the of the sprayer. This feature is typically used near fence lines, field borders, and boundaries where the outside spray sections cannot otherwise cover. When Fence Valve is selected, additional parameter options for adjusting tip size, coverage width, using on-screen activation buttons, and mapping application are presented.

Fence NCV. Select to designate the outermost NCV to project spray outward and beyond the working width of the of the sprayer. When active, the NCV will operate at 100% duty cycle. This feature is typically used near fence lines, field borders, and boundaries where the outside spray sections cannot otherwise cover. When Fence NCV's are set up, they are not included in the overall working width. For example, if there are 72 total NCV's installed, 70 NCV's x NCV spacing should be used the overall working width calculation.

Edge NCV. Select to designate the outermost NCV to project spray inward along the outer edge of the booms. When active, the outermost NCV will adjust duty cycle as speed and rate require and fill in coverage for the outside of the next inner-most NCV to prevent skips in coverage. When Edge NCVs are set up, they are not included in the overall working width. For example, if there are 72 total NCVs installed, 70 NCVs x NCV spacing should be used the overall working width calculation.

Fence + Edge NCV. Select to designate the outermost two NCV's on each side of the boom as Fence NCV's spraying outward and Edge NCV's spraying inward as described previously. These NCV's are not included in the overall working width. For example, if there are 72 total NCV's, 68 NCV's x NCV spacing should be used the overall working width calculation.

3. If available and desired, select the Enable On-Screen Fence Row Buttons option to toggle fence row application directly from the UT screen. If this feature is not activated, fence row sections must be toggled on or off by another switch or button.

NOTE: Both the desired fence row button/switch and the adjacent section or NCV must be turned on for the fence row valve to apply product.

This setting is only accessible via the profile calibration wizard.

4. Enable the Link Fence Rows with Outer Sections option to toggle fence rows only when the outermost section or NCV is also active. If this feature is not activated, fence rows may be toggled on or off independently of the adjacent or outermost section or NCV.
5. Enable map fence rows as sections to show additional applied area on the coverage map when fence rows are activated. When this feature is not activated, area covered by fence row sections will not be mapped when fence rows are toggled on.

NOTE: This setting is only accessible via the profile calibration wizard.

6. Enter the additional width covered when only one of the fence row sections is activated, and the spray boom is at the target height.

NOTE: This measurement assumes that both left and right fence row coverage patterns are equal. This setting is only accessible via the profile calibration wizard.

7. Set the tip size used for the fence row nozzles.

NOTE: Both left and right fence row tip sizes must be the same.

8. Select the Next button to continue to the Switch Mapping page.

SWITCH MAPPING

1. If available, use the drop-down fields for each configured section to assign the switch number for each section.
2. Optionally, if left and right fence rows will be controlled via input switches, select the available switch number used to control the fence rows.

NOTE: Each section must be assigned to a switch before the Next button will be displayed.

SECTION SETUP

1. If available, enter the width of each section configured for product control.
2. Select the Next button to continue to the Section Offsets page.

SECTION OFFSETS

1. Enable the Rear Implement option if the boom is mounted over or behind the rear axle of the machine or the pivot point of the pull-type sprayer. If the boom is mounted at the front of the sprayer, or in front of the rear axle, leave the Rear Implement option unchecked.
2. Measure the distance from the sprayer pivot point to the boom. For example, the center of the sprayer axle or the rear axle on a self-propelled sprayer to the boom. Enter the measurement in the "B" field in inches [centimeters].

NOTE: The value entered for the "B" distance must be measured parallel with the direction of vehicle travel.

3. Enable the Left of Center option if the boom is offset to the left of the centerline of the sprayer. If the boom is centered on the sprayer or is offset to the right, leave the Left of Center option unchecked.
4. If different sections have different fore/aft offsets for the same product, enable the Individual Sections Fore/Aft Offsets to allow the offsets to be configured for independent sections.

5. Measure the distance from the center of the boom to the centerline of the sprayer. Enter the measurement in the "A" field in inches [centimeters].

NOTE: The value entered for the "A" distance must be measured perpendicular to the direction of vehicle travel.

6. When configuring the system for a pull-type sprayer, measure the distance from the pivot point to the implement hitch. Enter the measurement in the "C" field in inches [centimeters].

NOTE: The value entered for the "C" distance must be measured parallel with the direction of vehicle travel.

7. Press Next to continue with the system calibration.

CALIBRATE INERTIALS

NOTE: If the Hawkeye® 2 system is not installed, the inertials calibration process will not be available. Skip to the *Pressure Sensor Setup* to proceed with the calibration wizard.

Only calibrate inertials when the ECU is securely mounted to the machine and the machine is stationary. It is important to minimize any movement or vibration caused by the engine, boom movement, wind, etc. which may cause a false sensor reading.

1. Review the on-screen instructions and confirm the arrow number pointing toward the ground.
2. Touch the Redetect Orientation button if ANY of the following occur:
 - If the Detected Orientation number does not match the actual downward direction number of the controller.
 - If the displayed Yaw Rate is a constant, non-zero number.
 - If the displayed Yaw Rate varies by more than +/- .3 degrees per second with the machine stationary.
3. When the Detected Orientation field matches the RCM - Sprayer ECU orientation, select the Next button to continue to the Pressure Sensor Setup page.

PRESSURE SENSOR SETUP

1. Use the Boom, Sparge, and Pump drop-down fields to select the type of pressure sensor or transducer connected to the Hawkeye® 2 system.

NOTE: Options for sensor type will automatically populate if the sensor is detected. If not detected but expected, see "Diagnostic Trouble Codes (DTCs)" on page 67 regarding pressure sensors not detected.

A boom pressure sensor must be installed on the machine for proper system operation. Other pressure sensor options will display if they are detected. Select None to disable or skip setup of the other pressure sensors.

2. Select the Next button to continue.

CONTROL VALVE TYPE

Select the Control Valve Type from the drop down list. A PWM control valve type is preferred for proper operation of the control system. Fast and Standard liquid control valve types are also available, but system performance may be affected.

PWM SETUP

If a PWM control valve is selected as the control valve, complete the following steps:

1. Enter the Coil Frequency of the hydraulic PWM pump control valve.
2. Enter the desired PWM High Limit % for the PWM pump control valve. Enter a value less than 100% to optimize pump performance.
3. Enter the PWM Low Limit % for the PWM pump control valve. Enter a value above 0% to prevent delayed pump output when spraying.
4. Select the desired Pump Standby Mode for when the product switch is on, but the system is not spraying:
 - Boom. System will maintain a target pressure in the boom. This option is not available if Sidekick Pro ICD injection pumps are detected.
 - Pump Pressure. System will maintain a target pressure at the pump. Enter a Standby Pressure Offset to increase or decrease the standby pump pressure by that amount. This option is only available if a pump pressure sensor has been configured.
 - Pump PWM. System will maintain a target pump PWM percentage.
 - Hold. System will maintain last control valve or pump PWM percentage when not spraying.

NOTE: When Sidekick Pro ICD injection pumps are detected, Standby Pump PWM is automatically selected. If a check valve is present on the main product line, Standby PWM should be enabled to prevent delayed pump output when transitioning toggling application on and off (e.g. turning the boom on and off in headlands or border passes).

5. Enter in the Standby Pressure Offset or Standby Pump PWM % value. A positive (+) pressure offset value increases the system pressure over what the target or minimum pressure is when not spraying. Standby PWM percentage should be between the PWM low and high limit values.

RATE SENSOR SETUP

1. Select the Flow Meter Calibration field and enter the calibration value for the flow meter used to monitor the product flow.
2. Select the units field and use the drop-down options to select the flow meter units.

NOTE: The flow meter calibration value and units are typically found on a tag or label affixed to the flow meter. Raven flow meters use a meter cal in pulses per 10 gallons [37.9 L]. Other manufacturers may use different meter cal units.

3. Enter the Flow Meter Low Limit value. This is the lowest specified reading of the flow meter and can be obtained from the manufacturer. Raven flow meter low limit values are as follows:
 - RFM 5 - 0.1 GPM (0.4 L/min)
 - RFM 15 - 0.5 GPM (1.9 L/min)
 - RFM 60 - 1.5 GPM (5.7 L/min)
 - RFM 100 - 3 GPM (11.4 L/min)
 - RFM 200 - 15 GPM (56.8 L/min)
4. If available, select the Tank Fill/Level Sensor that is currently installed. If a tank fill flow meter is selected, enter the meter cal and units for the sensor before proceeding with the calibration.
5. Select the Next button to continue to the Tank Fill Setup page.

TANK FILL SETUP

1. Touch the Tank Capacity field and enter the full volume of the main product tank.
2. Touch the Current Tank Level field and enter the current product volume in the tank.
3. Touch the Low Tank Level field and enter the volume at which the operator should be alerted to a low tank condition. Enable the Alarm option to allow the system to activate an audible alarm when the Low Tank Level is reached during field applications.
4. Touch the Max Tank Fill PWM field and enter the maximum duty cycle for the pump to refill the product tank.
5. Touch the Next button to continue to the Rates Setup page.

NOTE: Additional tank fill setup pages will be displayed for any additional Sidekick Pro ICD products detected on the system.

RECIRCULATION SETUP

NOTE: The Recirculation Setup is only displayed when the recirculation feature is unlocked.

1. Enable the Boom Recirculation check box if the boom is equipped with recirculation plumbing. Refer to *Boom Recirculation* section on page 40 for additional information regarding the recirculation feature.
2. Enable the Auto Recirculate check box to allow the system to automatically activate the boom recirculation feature when all boom sections are toggled off.

RATES SETUP

1. Enter Rate and Pressure Preset values that will be used during field applications to quickly change target application rate or pressures.

NOTE: Pressure preset values may only be entered if the Hawkeye® 2 NCV system is detected.

2. Touch the Rate Selection drop-down field and select the desired method for setting rates during field applications.

NOTE: This option may be changed after the initial calibration is complete. Refer to the *Rates Setup Tab* section on page 43, for additional assistance.

3. Enable the Display Smoothing feature to allow the system to smooth the product application rate display during field applications. Refer to the *Display Smoothing* section on page 43 for additional information about the Display Smoothing feature.
4. Touch the Next button to complete the initial setup and calibration of the Hawkeye® 2 system.
5. If additional injection products are detected, select the Radio Rate option to control the ratio of injected product volume to the carrier product volume, e.g., oz/gal or mL/L. If not selected, the injection product will control the injected product volume to the coverage area, e.g., oz/acre or mL/ha.

NOTE: Additional rate setup pages may be displayed for any additional products detected on the system.

FUNCTIONAL INSPECTION

Refer to the following sections for assistance with validating that the RCM - Sprayer and Hawkeye® 2 systems have been installed and calibrated properly.

SYSTEM FUNCTION

To verify that the system is functioning properly after installation:

1. Flush the main product tank and boom plumbing with clean water and verify the tank contains at least 100 gallons [379 L] of clean water.
2. Park the equipment in an area with enough space to unfold the booms and allows for visual inspection of the spray pattern from a moderate distance (e.g. 20 ft [6.1 m]).
3. If present, toggle the Hawkeye® 2 nozzle control system to manual mode and set both the control valve and NCV DC to 50%.
4. Access the manual Control Valve setting by pressing the PR1 tab on the Home screen. Access the NCV DC% setting by pressing the pressure tab on the Home screen.
5. If necessary, open the tank sump valve.
6. If present, turn on the machine pump switch.
7. Toggle the on-screen product on/off button to engage the product pump.
8. Toggle all section switches and the master switch.

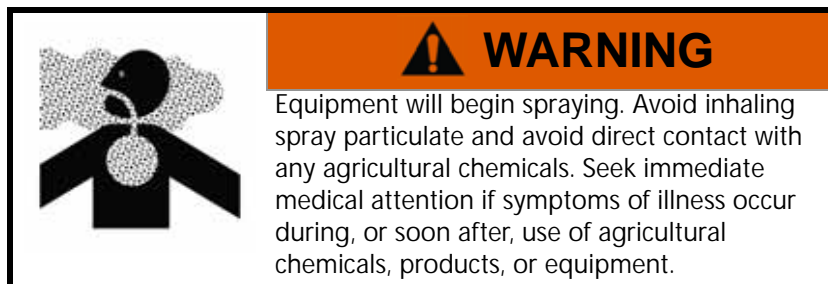

9. While maintaining a safe distance away from any spray and spray drift, visually check that all spray tips are spraying and, if present, all nozzle control valves are pulsing with a uniform pattern. Adjacent nozzle control valves should alternate pulsing. If adjacent NCVs are pulsing at the same time, refer to Chapter 9, *Troubleshooting*, for additional assistance.
10. On the UT, set the control valve to about 30%. For systems without NCVs, turn off the master switch and close section valves. For systems with NCVs, set the NCV DC % (duty cycle %) to 0% to close the nozzle control valves and maintain a safe pressure in the boom.
11. Visually check that none of the tips are spraying or dripping. Refer to *Testing for Leaks* section on page 125 for additional assistance and troubleshooting if leaks are observed.

TURN COMPENSATION FEATURE

NOTE: Turn compensation is only available for systems with the Hawkeye® 2 NCV system.

To verify the Turn Compensation feature is enabled and operating:

NOTE: Complete the procedure outlined in the *System Function* section on page 19 to validate the nozzle control valve function prior to performing the following procedure.

Turn Compensation is automatically calibrated during the calibration wizard. If the feature is not operating as described below, refer to the *Enable Turn Compensation* section on page 38 for assistance with calibrating the turn compensation feature if necessary.

1. Move the implement to an open area where the equipment may be driven in quick, tight turns.
2. Verify that the turn compensation feature is enabled.
3. Set the system to automatic mode and toggle the section and master switches to the on positions. Refer to Chapter 6, *Operation* for additional assistance with operation of the nozzle control system.
4. While driving at a speed between 5 and 10 mph [8 and 16 kph] and maintaining a safe working distance, observe the inner-most and outer-most spray tips while the implement is turning sharply.

NOTE: The NCV PWM percent value may also be used to monitor the operation of nozzle control valves across the spray boom. Refer to , *NCV Diagnostics*, for additional assistance with on-screen nozzle control valve diagnostics.

When turn compensation is enabled and the machine is turning, the nozzle control valves toward the outside of the corner will output a higher flow rate (higher PWM percent), while valves toward the inside of the corner will output a reduced flow rate (lower PWM percent) or may shut off. Average, Minimum, and Maximum NCV DC % output can be viewed by pressing the "Pressure" tab on the Home screen. NCV diagnostics and performance may be viewed in the NCV Readings display shown in the NCV Information menu. The difference between inner and outer flow rates will vary depending upon the machine speed, yaw rate, and implement width. Turn compensation may also be observed on the Diagnostics Info page. ECU Yaw Rate will be zero while stationary. The displayed yaw rate will be positive when the machine is turning to the right and negative when the machine is steering to the left.

5. If the operator is able to observe a difference in the spray pulsing, or the on-screen PWM percent, the turn compensation feature is working correctly. If there is no difference between the PWM percent values across the implement width, recalibrate the turn compensation feature and repeat the test.

TOOLS MENU OVERVIEW

System settings and options may be viewed by selecting the tabs displayed along the top of the Tools Menu.

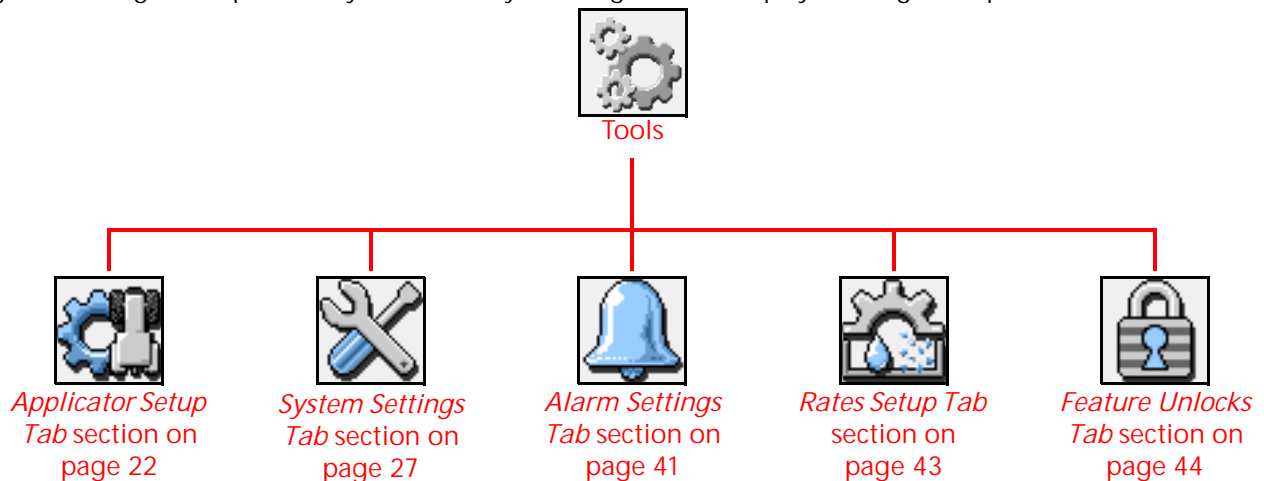

NOTE: Touch the Help icon on any page for additional information.



Help

Applicator Setup. Access the Applicator Setup page to edit or remove the RCM - Sprayer profile, review the section and precision farming setup information, and configure other application system settings such as tip size. Refer to *Applicator Setup Tab* section on page 22 for additional assistance with the Applicator Setup menu.

System Settings. Adjust the following product control settings and features:

- Control Valve Setup
- Rate Sensor Setup
- Tank Fill Settings
- Display Setup
- Pressure Setup
- NCV Information¹
- User Settings
- Pump RPM Calibration

¹. Not available in Bypass NCV control mode.

Alarm Settings. Access alarm settings for each product control channel on the system.

Rates Setup. Enter product Rate and Pressure preset values, rate selection or enable the display smoothing feature.

Feature Unlocks. Activate optional features of the Rate Control Module (RCM) - Sprayer control system. Contact a local dealer for additional information regarding available features and to purchase feature unlocks.

APPLICATOR SETUP TAB

PROFILE AND MACHINE TYPE

To review the current profile name and machine type:

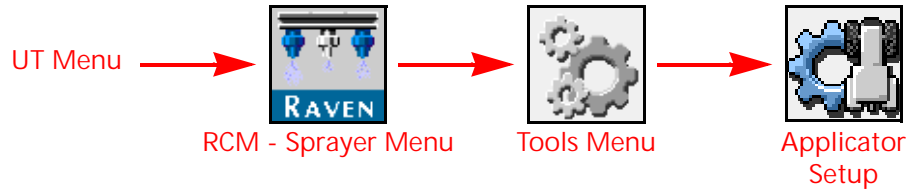

1. Open the UT Menu and select the RCM - Sprayer Menu button.
2. Select the Tools Menu softkey along the right side of the display.
3. Select the Applicator Setup tab along the top of the display. The name entered for the machine profile and the type of equipment selected during the initial system calibration will be displayed at the top of the Applicator Setup page.
 - Use the Change/New button to select a different profile or create a new profile for the machine in operation. Up to 8 unique profiles may be saved on the RCM - Sprayer ECU.
 - Use the Edit button to edit the selected profile.

NOTE: Some calibration settings are only available through the Machine Profile wizard and will require the equipment operator to edit the Machine Profile.

Some settings entered into a specific profile (such as tip information) will not be available if a different profile is selected.

- Use the Remove button to remove the selected profile from the system.

NOTE: A new profile must be created if a profile is deleted and there are no other profiles remaining in the selection list.

SECTION SETUP SUMMARY

To review the current section setup:

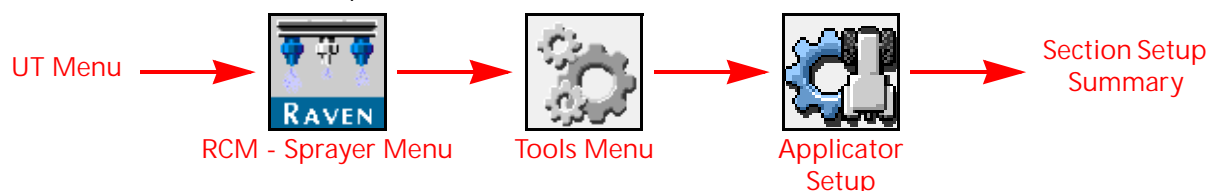

1. Open the UT Menu and select the RCM - Sprayer Menu button.
2. Select the Tools Menu softkey along the right side of the display.
3. Select the Applicator Setup tab along the top of the display.
4. Select the Section Setup Summary button. The Section Summary page will be displayed.

Page 1 of the Section Setup Summary displays the following section information for each product control channel configured on the system:

NOTE: Refer to the Chapter 3, *System Calibration*, to change the following section configuration.

Liquid Section Width. The width of each section associated with a boom valve, displayed in inches [centimeters].

Wired Signal Driver. Displays the “wired as” signal driver that controls the section.

Switch Number. The number of the switch to which the section is assigned.

Tip Spacing. The value and units set for nozzle body spacing is displayed in this field.

Page 2 of the Section Setup Summary displays the Section Auto-Operation Times. These values set the time each section will run for automated priming and recirculation functions. The maximum auto-operation time is 180 seconds.

FENCE ROW SETTINGS

To review the current section setup:

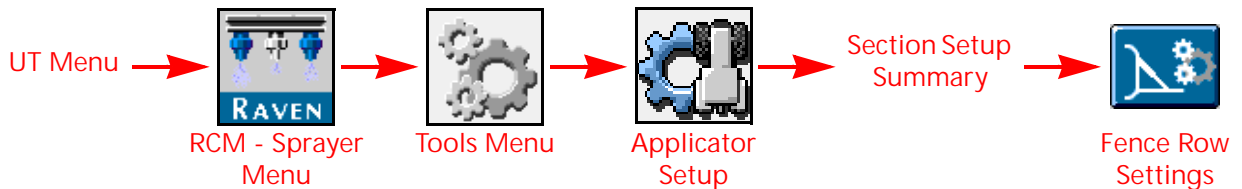

1. Open the UT Menu and select the RCM - Sprayer Menu button.
2. Select the Tools Menu softkey along the right side of the display.
3. Select the Applicator Setup tab along the top of the display.
4. Select the Section Setup Summary button. The Section Summary page will be displayed.
5. Select the Fence Row Settings icon. The following features and options will be displayed:

Enable On-Screen Fence Row Buttons. Select the Enable On-Screen Fence Row Buttons to allow the operator to toggle fence rows on and off via buttons displayed on the UT screen. When this option is disabled, fence rows must be activated via another switch or button on the machine.

NOTE: This feature may only be changed in the profile wizard.

Link Fence Rows with Outer Sections. Enable the Link Fence Rows with Outer Sections option to activate fence rows only when the outermost section or NCV is also active. When disabled, fence rows may be activated independently from the outermost section or NCV.

Map Fence Rows as Sections. Select the Map Fence Rows as Sections to show additional applied area on the coverage map when fence rows are activated. When left disabled, fence row area will not be mapped or calculated in the coverage area when fence rows are activated.

NOTE: This feature may only be changed in the profile wizard.

Fence Row Width. Enter the width covered when one of the fence rows is activated and the spray boom is at the target height.

NOTE: This value may only be edited in the profile wizard.

Fence Row Tip Size. If a spray tip is equipped on the fence row nozzles, select the tip size from the drop down list.

Fence Row Switch Assignments. If the On-Screen Fence Row Buttons is not used, select the switch number to which the left and right fence rows are assigned.

NOTE: These options are only editable when “Fence Valve” is selected for custom boom setups.

PRECISION FARMING SETUP WIZARD

Precision Farming Setup offers advanced section settings and features such as section overlap, on/off look-ahead values, and individual section fore/aft measurements for unconventional boom configurations.

To start the Precision Farming Setup:

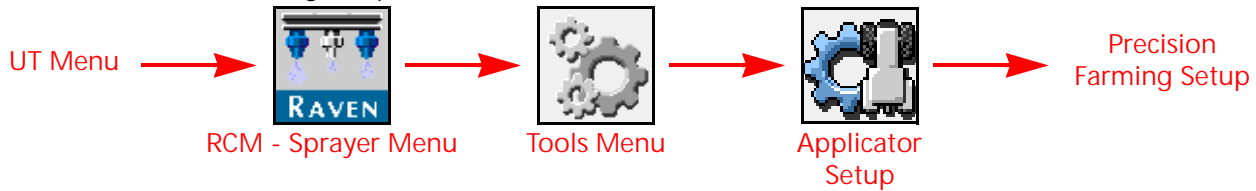

1. Open the UT Menu and select the RCM - Sprayer Menu button.
2. Select the Tools Menu softkey along the right side of the display.
3. Select the Applicator Setup tab along the top of the display.
4. Select the Precision Farming Setup button.

NOTE: Some UT displays or task controllers may not be compatible with precision farming settings.

Refer to Chapter 5, *Precision Farming Setup*, for additional assistance with completing the Precision Farming Setup Wizard.

NCV CONTROL MODE (SYSTEMS WITH HAWKEYE® 2)

NOTE: The NCV Control Mode is only available for RCM - Sprayer with Hawkeye® 2 systems and may only be changed outside of an active job. To change modes in the field, the operator will need to close the job, change the NCV control mode, and then reopen the job.

NOTE: When bypassing Hawkeye® 2 nozzle control system:

- NCVs will remain closed.
- Be sure to open manual shut off valves on each nozzle body and enter the appropriate tip size.

To change the NCV Control Mode:

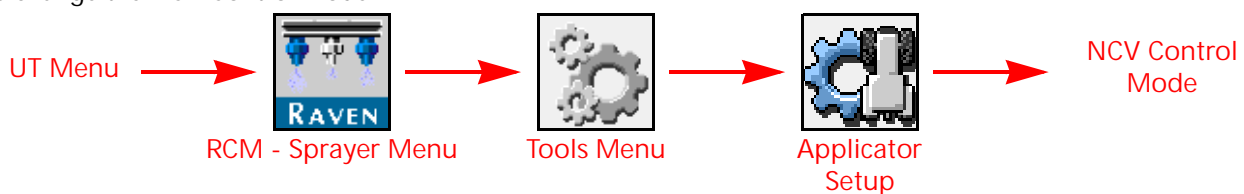

NOTE: Section and NCV control modes are also available via the Active Control Mode readout on the home page. Refer to *Readout Descriptions* section on page 33 for additional assistance with the available Display Settings.

1. Open the UT Menu and select the RCM - Sprayer Menu button.
2. Select the Tools Menu softkey along the right side of the display.
3. Select the Applicator Setup tab along the top of the display.
4. Use the drop-down list to select the appropriate NCV control mode. Review the *RCM - Sprayer Features* section on page 5 for information regarding the available options.

SECTION CONTROL MODE DISPLAY

To view the Section Control Mode configured during the System Calibration:

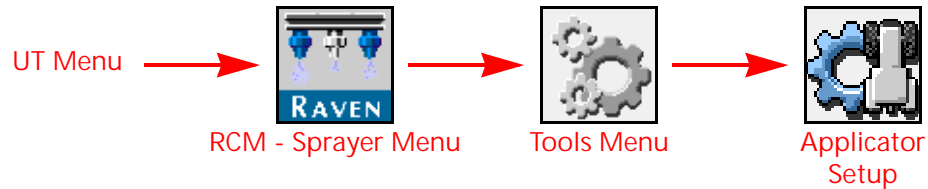

1. Open the UT Menu and select the RCM - Sprayer Menu button.
2. Select the Tools Menu softkey along the right side of the display.
3. Select the Applicator Setup tab along the top of the display. The following section control modes may be displayed:

- Boom Valve
- Virtual Section
- HD

The section control mode is automatically configured during the initial RCM - Sprayer calibration. Review Chapter 3, *System Calibration*, for assistance with completing the system calibration wizard.

NOTE: The highest available system nozzle resolution will be displayed based upon the operating mode and features unlocked.

SELECT TIP

SETUP NEW TIP PROFILE

NOTE: Up to 10 spray tip profiles may be saved. Spray tip profiles are available in all modes of NCV operation for a machine profile. Profiles entered in one machine profile are not available in other machine profiles. Tip profiles must be entered for each configured machine profile.

To setup a new spray tip profile for the RCM - Sprayer system:

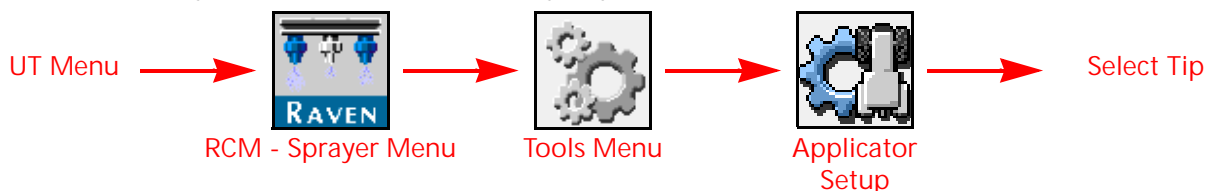

1. Open the UT Menu and select the RCM - Sprayer Menu button.
2. Select the Tools Menu softkey along the right side of the display.
3. Select the Applicator Setup tab along the top of the display.
4. Touch the Select Tip button. The Tip Selection page will be displayed. Use the following options and settings to assist with monitoring the droplet size during field applications.
5. Use the following options and settings to configure the control system to assist with droplet size monitoring.

NOTE: The NCV tip size is required. A bypass tip size is optional, depending upon the nozzle configuration installed on the machine. Refer to the *NCV Control Mode (Systems with Hawkeye® 2)* section on page 24 for additional details.

NCV or bypass tip size options may not be available in some NCV control modes. When set to bypass mode, the NCV tip size is not editable.

Select Tip and Tip Name. Use the drop-down list to:

- a. Set up a new spray tip that will be used with the system.
- b. Select a spray tip previously set up.

Enter a name (up to 12 characters) for the tips to allow the operator to quickly select the appropriate spray tips for the field application.

NOTE: The tip size profile will display as "---" if the NCV or bypass tip size is not editable based upon the selected NCV control mode.

Press the "X" button to delete the selected tip and to remove it from the Select Tip and Tip Name drop-down list.

NCV Tip Size. Select the size of the spray tips installed on the Hawkeye® 2 NCVs.

Droplet Size. Enter the published droplet size information available from the tip manufacturer for the tip size and series.

Minimum/Maximum Pressures. Enter the pressure range (minimum and maximum) for the spray tips installed to help maintain the desired droplet sizing.

NOTE: When entering pressure ranges for different droplet size classifications, ensure that the values entered are within the overall minimum and maximum spray pressure range set in the Pressure Setup Menu.

TEST SPEED AND TURN COMPENSATION

The Test Speed and Test Turn Compensation feature allows the operator to enter a simulated speed and turn for the system and allows the operator to check and verify system operation and functionality while the equipment remains stationary.

To enter a test speed:

NOTE: A test speed may also be entered via the Speed Readout on the Home page. Refer to the *Display Setup Menu* section on page 32 for assistance with customizing the Home tab displays.

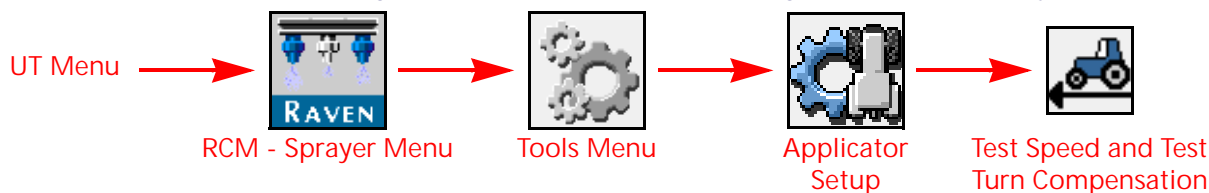

1. Open the UT Menu and select the RCM - Sprayer Menu button.
2. Select the Tools Menu softkey along the right side of the display.
3. Select the Applicator Setup tab along the top of the display.
4. Select the Test Speed button. The Test Speed page will be displayed.
5. Either enter the desired simulated speed or select the Resume Last Speed button to set the speed for testing system operation.

NOTE: Enter a test speed that is within the acceptable speed range for the system as setup. Entering a test speed above or below the recommended speed range may result in alarms or product shut down.

To use Test Turn Compensation:

1. Ensure a test speed is entered. The Test Turn Compensation option will appear.

- Enter a turn compensation turn rate or use the left and right arrow buttons to simulate a left or right turn. The arrow buttons will increase or decrease the turn rate by 0.1 degrees/second. Positive values indicate a right turn and negative values indicate a left turn.

NOTE: The Turn Compensation Test value will return to 0.0 and turn off when a speed test is set to 0.0 or normal driving resumes.

SYSTEM SETTINGS TAB

CONTROL VALVE SETTINGS AND TUNING

To tune the control valve or enable additional features and options:

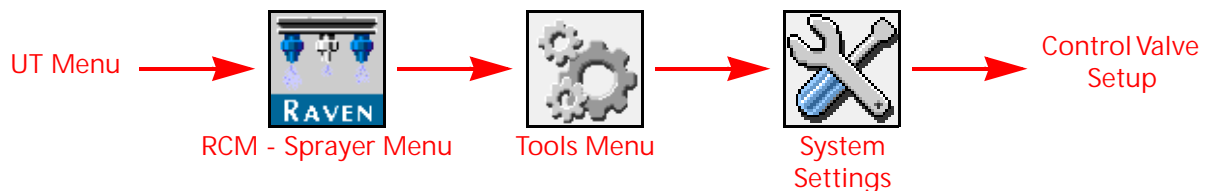

- Open the UT Menu and select the RCM - Sprayer Menu button.
- Select the Tools Menu softkey along the right side of the display.
- Select the System Settings tab along the top of the display.
- Select the Control Valve Setup button on the System Settings page. The following settings and options are available to help tune the control valve for the specific application system and to help improve applicator efficiency:

CONTROL VALVE TYPE

Displays the type of control valve selected for product control operations.

NOTE: The operator will have to either create a new machine profile or edit the existing profile to change the control valve type or enable some features of the product control system. Refer to Chapter 3, *System Calibration*, for additional assistance with completing the Machine Profile.

A PWM type control valve is preferred for proper operation of the RCM - Sprayer with Hawkeye® 2 nozzle control system.

NOTE: This setting can only be changed during system calibration.

VALVE RESPONSE RATE

The valve response rate determines how aggressively the system will adjust to changes in pressure, flow, and speed. This value has a range from 1 to 100.

If the system adjusts to rate control changes too slowly, increase the value to speed up the system response. If the system consistently overshoots the target rate or oscillates around the target rate, decrease the value to help stabilize the system.

NOTE: Avoid setting both the Valve Response Rate and NCV Response Sensitivity values above 70. Refer to the *NCV Response Sensitivity* section on page 29 for more information.

CONTROL DEADBAND

Enter a value between 0 and 9 to set the allowable difference between the target application rate and the actual rate. Rate correction is not performed as long as the application rate is within the allowable range.

Enter a value of 1 to set a ±1% tolerance between the target and actual application rates. A value of 9 equals a ±9% tolerance. The default rate control deadband value is 0%.

CONTROL VALVE PWM SETUP

The PWM Setup page allows the operator to tune PWM control and system response for the specific application system.

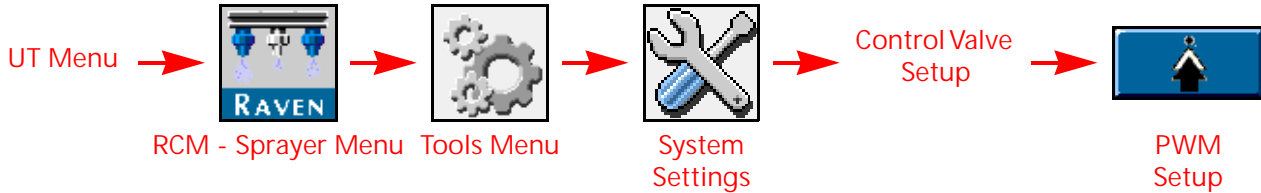

Coil Frequency. The default coil frequency is 60 Hz. Set the frequency of the PWM valve coil. Refer to the PWM control valve manufacturer specifications for the recommended PWM frequency.

PWM High Limit. Set the maximum desired output for a pump controlled by a pulse width modulated (PWM) hydraulic control valve. This setting limits how far the PWM valve will open.

With the machine section and master switches in the on position, increase this value until the maximum desired pressure is reached in a liquid system.

NOTE: The maximum operating pressure of the Hawkeye® 2 NCVs is 105 psi [724 kPa]. Adjusting the PWM high limit beyond the maximum response point of the valve will significantly reduce the expected service life of NCVs on the system and result in control response delays at the upper end of the system capacity range.

PWM Low Limit. Set the minimum desired output (zero point or shutoff point) for a pump controlled by a pulse width modulated (PWM) hydraulic control valve.

NOTE: Adjusting the PWM low limit below the minimum response point of the valve will result in control response delays at the low end of the system capacity range.

PWM High Side Drive. When enabled, this feature allows the system to modulate the high side (+) of the driver while providing a constant ground return. Most commonly used when a PWM boost box is installed.

MINIMUM NCV PWM

NOTE: Minimum NCV PWM is not available when operating in the Bypass NCV control mode.

Enter a minimum PWM percent to set the minimum desired output (zero point or shutoff point) for the Hawkeye® 2 nozzle control valves.

	<p style="text-align: center;">CAUTION</p> <p>Operating at an insufficient NCV PWM may result in under application or skips in coverage.</p>
--	---

With the machine master switch in the on position, decrease this value until the minimum desired spray pattern is reached in the liquid system.

NOTE: To help avoid under application or skips in coverage, review Appendix A, *Avoiding Skips with Hawkeye® 2 Nozzle Control System*, and maintain the recommended application conditions.

NCV RESPONSE SENSITIVITY

NOTE: Not available in NCV Bypass or On/Off control mode.

The NCV response sensitivity controls how sensitive the system is to changes in pressure, flow, and speed. Decrease sensitivity if system pressure and rate oscillate slightly. Increase sensitivity if control is unresponsive. Avoid setting sensitivity above 70.

STANDBY MODE

Select the desired Standby Mode and Standby Pressure Offset for when the product switch or pump is on, but the system is not spraying, to maintain a boom or pump pressure in the system for agitation, recirculation, or to ensure boom pressure does not drop when spraying resumes.

Boom Pressure. System will maintain a target boom pressure. When in Standard or High Flow NCV Control modes, the target spray pressure value from the home screen will be used as the standby pressure when not spraying. When in any other control mode, the minimum pressure will be used as the target boom pressure when not spraying. Any value entered in for Standby Pressure Offset will add to the target pressure, and the system will maintain that pressure when not spraying.

NOTE: For example, if the target spray or minimum pressure is 30 psi, and a 5 psi Standby Pressure Offset is entered, the boom pressure will be maintained at 35 psi when not spraying.

Pump Pressure. System will maintain a target pump pressure. This option is not available if a pump pressure sensor is not configured. When in Standard or High Flow NCV Control modes, the target spray pressure value from the home screen will be used as the standby pressure when not spraying. When in any other control mode, the minimum pressure will be used as the target pump pressure when not spraying. Any value entered in for Standby Pressure Offset will add to the target pressure, and the system will maintain that pressure when not spraying.

NOTE: For example, if the target spray or minimum pressure is 30 psi, and a 5 psi Standby Pressure Offset is entered, the pump pressure will be maintained at 35 psi when not spraying.

Pump PWM. System will maintain a target pump PWM% when not spraying. This is the default standby mode when direct injection or boom recirculation are configured on the system. For best results when spraying resumes, adjust the pump PWM to be no less than the pump PWM readout when actively spraying.

Hold. System will hold the last control valve position or PWM% when not spraying.

RATE SENSOR SETUP

To adjust rate sensor and tank fill sensor calibration values and units:

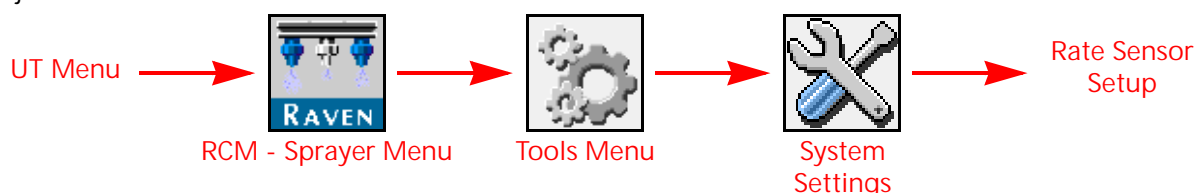

1. Open the UT Menu and select the RCM - Sprayer Menu button.

2. Select the Tools Menu softkey along the right side of the display.
3. Select the System Settings tab along the top of the display.
4. Select the Rate Sensor Setup button on the System Settings page. The following settings and options are available to help improve applicator efficiency.

FLOW METER CALIBRATION

Enter the calibration value for the flow meter used to monitor the flow of product to boom sections.

The flow meter calibration value and units are typically found on a tag or label affixed to the flow meter.

NOTE: Be sure to select the appropriate units for the flow meter calibration to ensure proper calibration of the application system.

FLOW METER PULSE/UNITS

Select the units for the flow meter from this drop-down list. The pulses/units is the number of pulses that the flow meter will generate for a given amount of product measured by the flow meter.

For example, a flow meter calibration value of 710 and a Pulse/Units value of 10 L indicates that 10 liters of product is measured through the flow meter for every 710 pulses of the flow meter.

NOTE: Raven flow meters use a meter cal in pulses per 10 gallons [37.9 L]. Other manufacturers may use different meter cal units.

FLOW METER LOW LIMIT

The minimum flow rate which the flow meter can read accurately. When the flow rate is below this setting, the flow will be calculated based off the pressure and tip size.

NOTE: Refer to the flow meter manufacturer's specifications when setting the low limit. Flow limits for Raven RFM flow meters can be found in "Rate Sensor Setup" on page 29.

TANK FILL FLOW METER CALIBRATION

NOTE: The optional tank fill system is not required for RCM - Sprayer operation and may not be installed on all equipment with these application control systems.

The fill system flow meter calibration value and units may be found on the tag attached to the flow meter installed in the fill system plumbing.

NOTE: Be sure to select the appropriate units for the flow meter calibration to ensure proper calibration of the tank fill system.

TANK FILL FLOW METER PULSE/UNITS

NOTE: This feature is not available with injection product control channels.

Select the units for the flow meter from this drop-down list. The pulses/units is the number of pulses which the flow meter will generate for a given amount of product measured by the flow meter. The fill meter calibration, or meter cal, value and units may be found on the tag attached to the flow meter installed in the tank fill system.

For example, a flow meter calibration value of 710 and a Pulse/Units value of 10 L indicates that 10 liters of product is measured through the flow meter for every 710 pulses of the flow meter. Be sure to select the appropriate units for the flow meter calibration to ensure proper calibration of the tank fill system.

NOTE: Raven flow meters use a meter cal in pulses per 10 gallons [37.9 L].

Copy the information from the tag for future reference as tags may fade or be lost during operation.

TANK FILL SETTINGS

To adjust tank fill system settings:

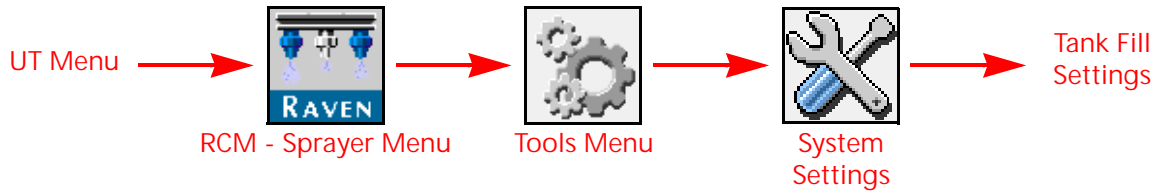

1. Open the UT Menu and select the RCM - Sprayer Menu button.
2. Select the Tools Menu softkey along the right side of the display.
3. Select the System Settings tab along the top of the display.
4. Select the Tank Fill Settings button on the System Settings page. The following settings and options are available to configure tank settings for the main product or injection products.

TANK CAPACITY

Enter the maximum tank capacity. The tank level indicator on the home screen uses the maximum tank capacity and current tank level values to display the level of product remaining in the tank.

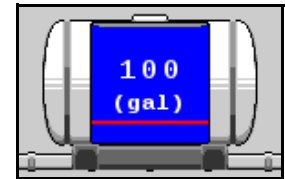

NOTE: Tank capacity value cannot be changed during an active job.

CURRENT TANK LEVEL

Manually set or adjust the product volume in the tank. This feature may be useful to manually set the tank level if products are added through the top of the tank, to correct the volume for a known amount of product added to the tank, or to adjust the tank level to a different value other than the full tank capacity.

Either enter the current tank level manually upon refilling the tank or use the tank fill flow meter to automatically measure the amount of product added to the tank.

LOW TANK LEVEL AND LOW TANK ALARM

Enter the low tank threshold to provide an indicator at the level which the tank is nearing empty. If the Alarm option is enabled for the low tank threshold, an audible alarm will be activated when the calculated volume remaining in the tank reaches the set threshold.

PRODUCT TYPE

Select Water-Based or Fertilizer for the type of product applied. The system will compensate for the different flow characteristics of each liquid.

NOTE: The meter cal may need to be adjusted when changing product types. Refer to the *Flow meter Re-Calibration* section on page 114.

MAX TANK FILL PWM

Set the maximum desired output for the tank fill pump controlled by a pulse width modulated (PWM) hydraulic control valve. This setting limits how far the PWM valve will open.

DISPLAY SETUP MENU

The machine operator may customize the readouts displayed on each product rate control tab and the pressure tab shown on the Home page.

FIGURE 1. Home Page Display Tabs

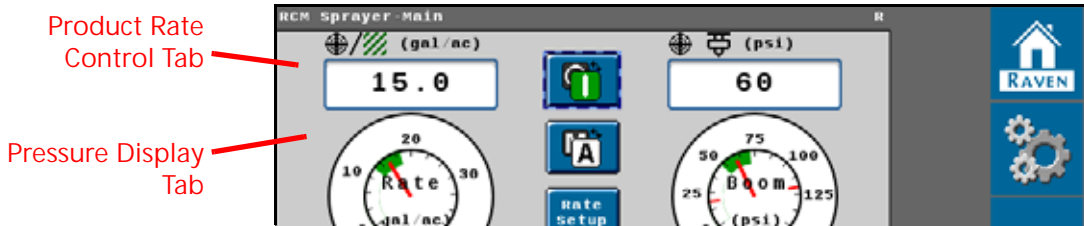

NOTE: When viewing tabs on the Home page, tapping the selected tab again will display the "Rates Setup" options for that product.

To customize the information displayed on the Home page of RCM - Sprayer system:

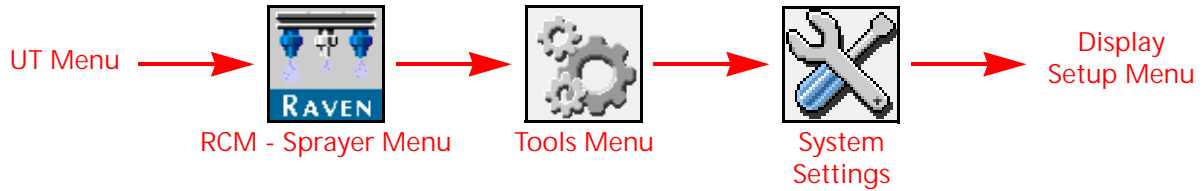

1. Open the UT Menu and select the RCM - Sprayer Menu button.
2. Select the Tools Menu softkey along the right side of the display.
3. Select the System Settings tab along the top of the display.
4. Select the Display Setup Menu button on the System Settings page. The Display Setup page is displayed.

FIGURE 2. Display Setup Page

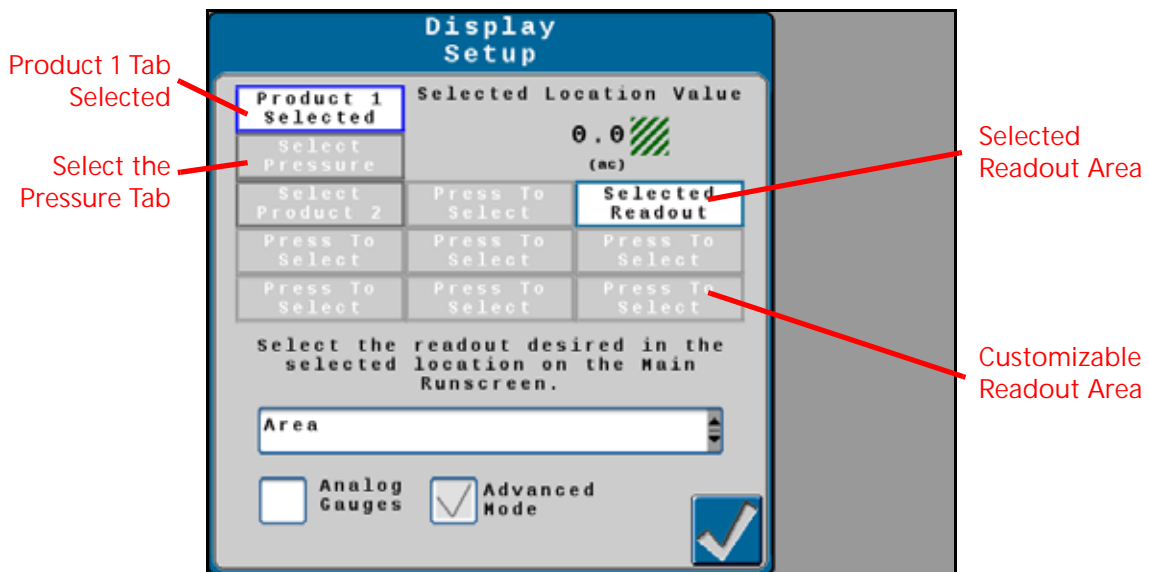

- Use the Tab Selection buttons starting in the upper, left area of the Display Setup page to select which Home page tab to customize.

NOTE: Slots for the Product 1 and Pressure tabs are reserved and will display readouts regardless of control mode. Additional products (e.g. injection) will take up slots in the left column and bottom of the "Display Setup" page.



- Next, select the readout area and use the drop down list to set the readout to display in the selected area.
- Enable Advanced Mode view to display up to 9 configurable readout area buttons. The default display mode is the Basic view, which only allows 3 configurable readout buttons. Basic display view is not available when chemical injection is configured.
- Enable the Analog Gauges option to toggle product information on the rate control tabs as gauges.
- Touch the Accept button in the lower, right corner of the page to accept the current readout selections and return to the System Settings tab.

NOTE: The Display Setup page can also be accessed by Rates Setup page. Find the Rates Setup page in the Product Rate Control tab.

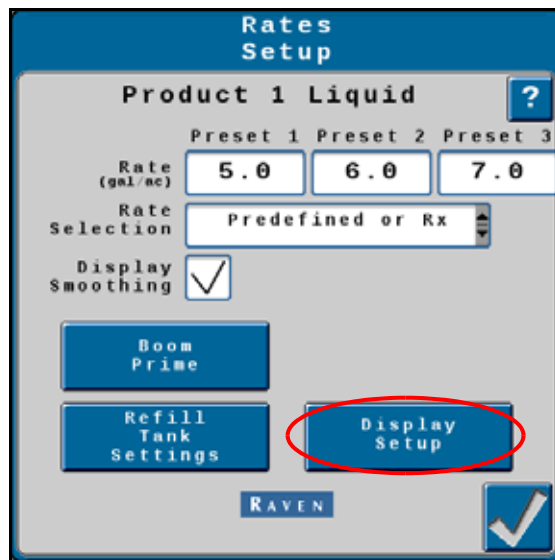
FIGURE 3. Rates Setup Page

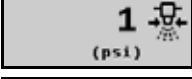
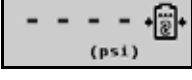
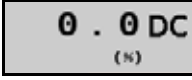

READOUT DESCRIPTIONS

-  No Readout. Select the No Readout option to leave the selected area empty.
-  Area per Hour. Uses the implement width and current implement speed to calculate the rate at which field area is covered.
-  Area Remaining. The field area remaining for the current job in progress.
-  Boom Pressure. Monitored pressure of the spray boom. This pressure is used as the control system pressure for spraying and alarm conditions.
-  Sparge Pressure. The current pressure of the sparge or tank agitation system.
-  PWM Readout. The control duty cycle of the PWM control valve which controls the product pump.

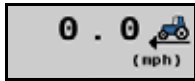

Speed Readout. The current speed over ground of the machine.

NOTE: Press and hold the machine button to enter a self test speed. Review the "Test Speed and Turn Compensation" on page 26 for additional information on using this feature.

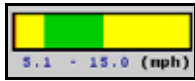

Recommended Speed. The recommended speed range to maintain the target rate and pressure settings. The area displayed in green represents the speed range (e.g., 5.1 - 15.0 mph). The red line indicates the current speed. The overall range of the graphic is 0 - 30 mph [0 - 48 km/h]. If the equipment speed is outside of the speed range, an alarm condition may be encountered and the control system may be unable to maintain the desired application rate or pressure.

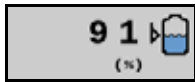

Tank Level Percentage. Percentage of the total tank volume remaining in the product tank.



Area. The field area covered during the current field application.



Total Volume Applied. The total product volume applied for the specific product displayed.



Volume per Minute. The instantaneous rate of product applied during field applications.

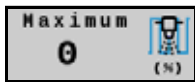

NCV Max Duty Cycle. Highest duty cycle percentage for NCVs on the system.

NOTE: Max Duty Cycle is not available in the Bypass NCV control mode.

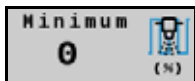

NCV Min Duty Cycle. Lowest duty cycle percentage for NCVs on the system.

NOTE: Min Duty Cycle is not available in the Bypass NCV control mode.

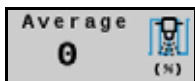

NCV Avg Duty Cycle. The average duty cycle for all NCVs on the system.

NOTE: Avg Duty Cycle is not available in the Bypass NCV control mode.

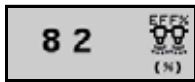

NCV Efficiency. The NCV Efficiency value compares the expected and actual system values for a tip size for the following parameters: NCV duty cycle, flow rate, and pressure.

NOTE: NCV Efficiency is not available in the Bypass NCV control mode.

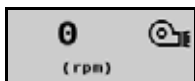

Pump RPM. The RPM of the product pump (if available and configured).



Active Control Mode. The active system NCV Control Mode and Section Control Mode.

NOTE: Press the Active Control Mode display to access the control mode and section control mode options.



Estimated Tip Pressure. The estimated pressure at the spray tips when spraying. This pressure will be less than or equal to the displayed boom pressure due to pressure losses through the system plumbing, nozzle body, and PWM valve if equipped. May be used to compare and adjust the target boom pressure to achieve the desired spray pattern and tip performance.



Pressure Presets. Shows the first two of three pressure presets from the Rates Setup menu.

NOTE: Pressure presets are not available in Bypass NCV control mode.

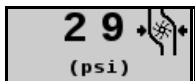

Pump Pressure. The current pressure at the outlet of the solution pump.

NOTE: Not available if a pump pressure sensor is not configured.

PRESSURE SETUP

To adjust pressure settings:

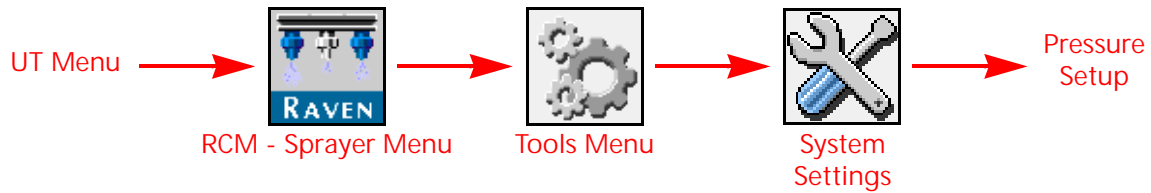

1. Open the UT Menu and select the RCM - Sprayer Menu button.
2. Select the Tools Menu softkey along the right side of the display.
3. Select the System Settings tab along the top of the display.
4. Select the Pressure Setup button on the System Settings page. The following pressure settings will be available:

BOOM, SPARGE, AND PUMP PRESSURE SENSORS

Use the drop-down menus to select the proper operating range of the installed pressure transducer sensors. Disconnecting the sensor and selecting None will disable the sensor and any alarms associated with it.

NOTE: A boom pressure transducer is required for system operation.

MINIMUM BOOM PRESSURE

The minimum boom pressure feature sets the lowest allowable boom pressure to which the product system will control during applications. If the application system reaches the minimum pressure setting, the system will maintain the flow rate to keep the monitored pressure consistent. This feature may be used to help maintain boom pressure and the nozzle spray pattern if product application rates and equipment speeds are close to the low end of the suggested ranges.

NOTE: Default minimum is 20 psi [137.9 kPa].

The minimum pressure feature may result in higher than desired application rates. If the minimum pressure feature will be used during field applications, be sure to enter a value that will not interfere with normal target rates or target pressures.

NOTE: Enable the minimum boom pressure alarm to enable an audible alarm when the minimum boom pressure threshold is reached.

MAXIMUM PRESSURE

The maximum boom pressure feature sets the highest allowable boom pressure to which the product system will control during applications. If the application system reaches the maximum pressure setting, the system will maintain the flow rate to keep the monitored pressure consistent at or below the maximum pressure.

NOTE: The maximum pressure feature may result in lower than desired application rates. If the maximum pressure feature will be used during field applications, be sure to enter a value that will not interfere with normal target rates or target pressures.

NOTE: Enable the maximum boom pressure alarm to enable an audible alarm when the maximum boom pressure threshold is reached.

The maximum recommended boom pressure for Hawkeye® 2 NCVs is 120 psi [827 kPa].

NCV INFORMATION

NOTE: NCV information and readings are not available in the Bypass NCV control mode.

To view NCV information:

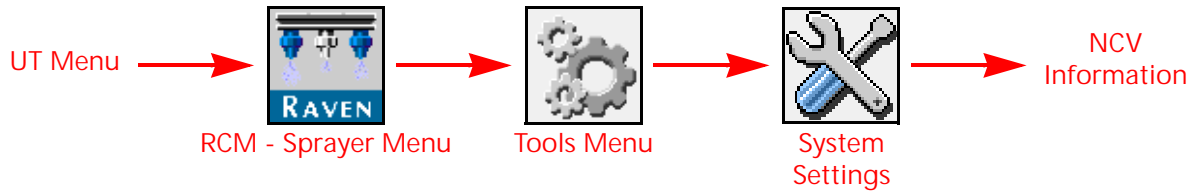

1. Open the UT Menu and select the RCM - Sprayer Menu button.
2. Select the Tools Menu softkey along the right side of the display.
3. Select the System Settings tab along the top of the display.
4. Select the NCV Information button on the System Settings page. The following items and menu options will be available:

SELECT SECTION

Entered the desired section number to inspect or scroll through the sections with the arrow buttons.

SECTION STATUS

Reflects the current operating status of the NCVs in the selected section.

- Green - All NCVs in the section are operating normally.
- Yellow - One or more of the NCVs in the section have an error and may require inspection.
- Red - One or more of the NCVs in the section are offline and may require inspection.

SELECT NCV

Enter the desired NCV number to inspect or scroll through the NCVs with the arrow buttons.

NCV STATUS

Reflects the current operating status of the selected NCV.

- Green - NCV is operating normally.
- Yellow - NCV has an error and may require inspection.
- Red - NCV is offline and may require inspection. May also indicate that the system is set to the NCV Bypass control mode.

NCV READINGS

NOTE: Not available in Bypass NCV control mode.

Displays readings from the selected NCV as well as software and hardware information.

NCV ERRORS

NOTE: Not available in the Bypass NCV control mode.

Displays any active NCV errors detected on the system.

NCV HEAT MAP

NOTE: Not available in the Bypass NCV control mode.

Shows an error status chart of the individual NCVs. Review the *NCV Status* section on page 36 for details about the NCV status displayed on the heat map.

SECTION HEAT MAP

Shows an error status chart of the sections. Review the *Section Status* section on page 36 for details about the section status displayed on the heat map.

NCV SETTINGS

Override NCV Off. Enable for the selected NCV to turn off flow from the NCV. The NCV will still show coverage to prevent future application in that area. Actual applications rates and volumes are accounted for to ensure correct rates on active NCVs.

Override Coverage Off. Enable after enabling Override NCV Off to turn off the covered area by the individual NCV. The affected area may show up as a strip on the coverage map. If the system passes over that area later for headlands or border passes, NCV will turn on and attempt to fill in that strip. Actual application rates and volumes are accounted for to ensure correct rates on active NCVs.

USER SETTINGS

To access additional operating and diagnostic features:

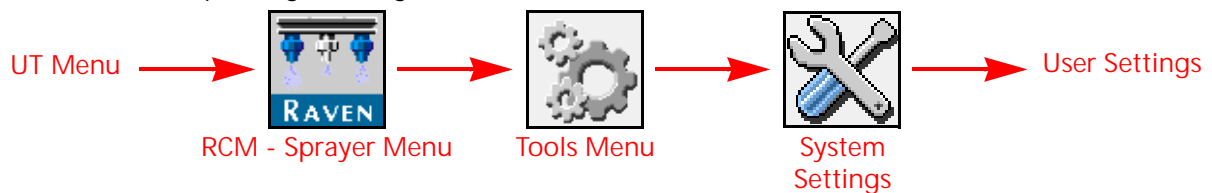

1. Open the UT Menu and select the RCM - Sprayer Menu button.
2. Select the Tools Menu softkey along the right side of the display.
3. Select the System Settings tab along the top of the display.
4. Select the User Settings button on the System Settings page. The following options are available:

WIRELESS CONTROL MODE

The wireless control mode enables the machine operator to perform system checks and maintenance outside of the cab using the Section Control Remote 2.0. Select one of the following modes for the wireless control feature:

Off. (Default) Turn off wireless control and disable remote access to the RCM - Sprayer system.

Section. The operator may use a connected wireless remote device to control boom section valves and NCVs associated with each boom section.

NCV. This mode will allow a compatible wireless remote device to control individual NCVs.

AUTO SECTION CONTROL

Enable the Auto Section Control option to allow the ISO task controller to automatically control boom sections based upon previous coverage maps to turn an active section when the section enters into an area where product has already been applied. As a section leaves previously applied area, the section control feature will automatically turn the section back on. When this option is disabled, section control commands from the task controller will be ignored.

NOTE: A task controller capable of automatic section control is required to allow the RCM - Sprayer system to control sections automatically. If the Auto Section Control is not enabled, section control commands from the task controller will be ignored. Refer to the manufacturer operation guides and materials for information on utilizing this feature.

- If the task controller is capable of automatic section control and the section control feature is available in the RCM - Sprayer Tools Menu, select the feature by placing a check mark in the corresponding box to enable the feature.
- If the task controller is capable of automatic section control, but the section control feature is not available in the RCM - Sprayer Tools Menu, the feature must be enabled from a different UT menu. Review the UT operation manual for assistance with the section control or task controller options.
- If the task controller is not capable of automatic section control, Hawkeye® 2 will not automatically control sections regardless of the state of the section control feature on this screen. It is recommended to de-select or disable this feature when operating the Hawkeye® 2 system without automatic section control.

GROUP END NCVS

NOTE: Not available in the Bypass NCV control mode.

Enable this option to link the three NCVs at the end of the boom to the NCV immediately beside them. When one of the NCVs are turned on, all linked NCVs will turn on. This feature may be helpful in areas with poor GPS coverage to prevent the end NCVs from flickering on and off.

ENABLE TURN COMPENSATION

NOTE: Not available in the Bypass NCV control mode.

The turn compensation feature allows for even application while the machine is negotiating curves and turns in the field. This feature automatically adjusts individual Hawkeye® 2 NCVs duty cycles to compensate for the yaw rate while the operator is steering the vehicle around obstacles, curved swath paths, or turns in the field.

The lowest NCV duty cycle may match the Minimum Nozzle PWM value for the innermost operating Hawkeye® 2 NCV in a turn. The highest NCV duty cycle may not be 100% due to maximum output capabilities of the Hawkeye® 2 NCV with a given tip size and system efficiency.

To enable the turn compensation feature:

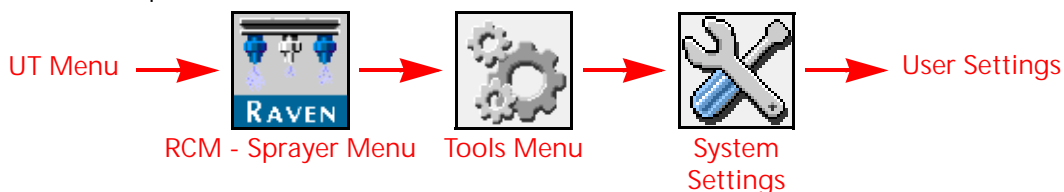

1. Open the UT Menu and select the RCM - Sprayer Menu button.
2. Select the Tools Menu softkey along the right side of the display.
3. Select the System Settings tab along the top of the display.
4. Select the User Settings button.

5. Touch the check box to toggle the Enable Turn Compensation.

Turn Compensation Calibration. If the RCM - Sprayer ECU mounting position is modified or adjusted, recalibrate turn compensation to ensure the feature correctly adjusts Hawkeye® 2 NCV rates during applications and ensure that the ECU orientation is configured properly.

NOTE: The ECU orientation is calibrated during the initial system calibration wizard. To recalibrate the ECU gyro, edit the profile or perform the following procedure.

To recalibrate the turn compensation feature:

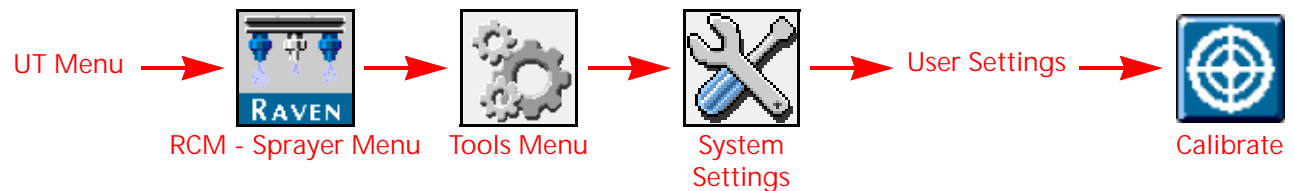

1. Move the equipment to a known level location.
2. Open the UT Menu and select the RCM - Sprayer Menu button.
3. Select the Tools Menu softkey along the right side of the display.
4. Select the System Settings tab along the top of the display.
5. Select the User Settings button and then select the Calibrate button. The system will recalibrate the ECU and set the ECU orientation.

QUICK START SECONDS

Enter the number of seconds to override sections status after the automatic section control override feature is enabled. When the quick start is enabled, any sections set to automatic control will turn on for the time entered as the quick start seconds value.

NOTE: Any sections set for manual control, or toggled on or off manually, will not be affected by the quick start seconds feature.

This feature may be useful to start application with the equipment at a complete stop or to manually override sections on for a brief time.

NOTE: The default quick start seconds value is 15 seconds. The quick start seconds value may only be changed without an active application in progress. If a Raven Viper 4 field computer is installed with the system, the operator may use the on-screen widget to change the override seconds.

Quick start will only activate sections set for automatic section control. Any sections configured for manual control, or set on or off manually, will not be affected by the quick start feature.

BOOM RECIRCULATION

NOTE: The boom recirculation feature requires boom plumbing and electrical harnessing to be compatible with this feature. If direct injection products are detected on the system, the boom recirculation feature cannot be enabled.

This feature must be unlocked and enabled by editing or creating a new machine profile through the profile wizard.

The recirculation button is displayed in the lower portion of the home page for product 1 for the main product tank.

Boom
Recirculation



When this feature is enabled, a recirculation valve will allow product to circulate from the main product tank, through the boom system, and back to the main tank using the main product pump. The recirculation can be manually or automatically enabled when no sections are enabled for applying product (active section width is zero).

When enabled, each section valve opens sequentially beginning with the outermost section valves and progressing toward the center of the boom. Once all sections have recirculated for the set auto-operation time for each section group, the recirculation sequence will repeat until the recirculation system is shut off or active product application resumes.

Select the Section Auto-Operation Time button to enter or adjust the section recirculation times as needed to ensure each section is recirculated adequately.

When this feature is enabled, the product pump is enabled, and the active section width is zero (no sections applying product), select recirculation button in the lower portion of the home page to initiate boom recirculation.

AUTO-RECIRCULATION

Enable the auto recirculate option to allow the system to automatically start the recirculation sequence when the active section application width is zero (all sections turned off). If the auto recirculate feature is not enabled, the operator must activate recirculation manually through a button on the UT.

NOTE: Whether set for manual or automatic recirculation, recirculation will automatically turn off when spraying resumes.

WHAT TO EXPECT WHILE RECIRCULATION IS ACTIVE

NOTE: When operating in Auto Recirculation Mode, it is recommended to adjust the Standby PWM% value so that recirculation pressure is close to the application pressure used during application.

When recirculation is active:

- The main product pump runs at the "Standby PWM%" value.
- Section valves will cycle "On" sequentially in pairs from the outermost to innermost sections for the user defined recirculation time.

NOTE: NCVs on each section will remain off.

- The system will continue to monitor the main flow meter to ensure product is circulating. If the product recirculation is less than the low limit of the flow meter, the system will display an alert, but recirculation will continue.
- The boom pressure transducer is monitored to ensure the system pressure stays within the minimum and maximum allowable pressures. The main product pump will shutdown if the boom pressure exceeds the minimum (6 PSI) or maximum (150 PSI) pressure.
- Section valves will continue to cycle sequentially unless spraying or shutdown conditions are met.
- The drain valve will be used to drain out any product in the recirculation line when rinsing the boom.

NOTE: It is recommended to rinse the system with the boom unfolded to prevent circulating with pinched supply hoses.

PUMP RPM CALIBRATION

Pump RPM Calibration. Sets the number of pulses per revolution of the pump if a speed sensor is installed on the pump.

Pump RPM Minimum and Maximum and Alarm Checkbox. Sets the rotational speed range of the pump. If the alarm checkboxes are selected, the system will alert the operator when the pump RPM exceeds the entered range of pump speed operation.

ALARM SETTINGS TAB

To access the Alarm Settings tab:

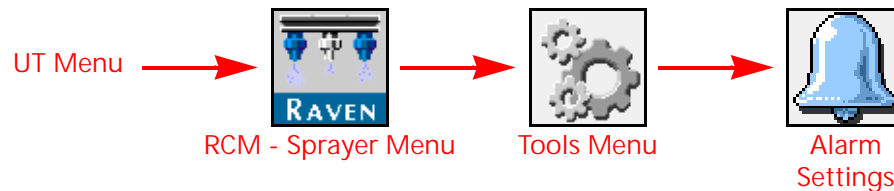

1. Open the UT Menu and select the RCM - Sprayer Menu button.
2. Select the Tools Menu softkey along the right side of the display.
3. Select the Alarm Settings tab along the top of the display.
4. Use the Product Channel buttons along the top of the page to select the desired product for the following alarm options and settings:

NOTE: Alarm settings must be set for each product channel on the system.

OFF PRESSURE ALARM

Toggle the check box option at the far right to enable or disable the Off Pressure Alarm.

When enabled, enter a value between 1 and 100 percent for the allowable difference between the target and actual product pressure. If the difference between the actual and target pressure exceeds the set percentage for more than 5 seconds, the system will display the off pressure alarm for the product.

OFF RATE ALARM

Toggle the check box option at the far right to enable or disable the Off Rate Alarm.

When enabled, enter a value between 1 and 100 percent for the allowable difference between the target and actual product application rate. If the difference between the actual and target rate exceeds the set percentage for more than 5 seconds, the system will display the off rate alarm for the product.

NCV EFFICIENCY % ALARM

NOTE: Not available for Bypass or On/Off NCV control modes.

NCV efficiency compares the NCV duty cycle to flow rate and pressure. Toggle the check box and enter a non-zero value to enable the NCV Efficiency alarm. Typical range is 90 - 105%.

For higher values:

- Check pressure and flow meter calibration
- Check tip selection
- Inspect for leaks in boom plumbing, fence rows left on, or for NCVs stuck open

For lower values:

- Check pressure and flow meter calibration
- Check tip selection
- Inspect for NCVs stuck closed or a flow restriction

UNEXPECTED SYSTEM FLOW CHANGE

NOTE: This alarm is only available in Bypass and On/Off operation modes.

When enabled, the system change detection alarm allows the system to notify the operator if the calculated system output flow is modified from learned values. Common situations that might cause this alarm to display are if the tips have been changed recently on the system or if an unexpected leak or restriction has been introduced in the system plumbing.

STUCK POPPET

NOTE: Not available in the Bypass or On/Off NCV operation modes.

When enabled, the stuck poppet alarm option allows the system to notify the operator if an Hawkeye® 2 NCV on the system does not detect movement of the poppet. The system will display an alarm and indicate which Hawkeye® 2 NCV is affected.

When additional products are detected, injection-specific alarms may be present for those additional products.

DI Efficiency Limit. When enabled, the injection pump detects the actual vs. expected output and notifies the user when the pumping efficiency is out of range. Typical values are from 60-90% and can vary based on chemical used. Low efficiency values may indicate that maintenance is required, a flow restriction exists, or the chemical is thick. High values may indicate calibration or maintenance is required.

High Inlet Vacuum. When enabled, the injection pump detects when the maximum pump inlet vacuum has been exceeded. If triggered, there may be a restriction in the plumbing between the injection pump inlet and the supply tank such as a plugged strainer, closed valve, or a supply hose issue. Some thick chemicals may also trigger the alarm.

RATES SETUP TAB

To access the Rates Setup tab:

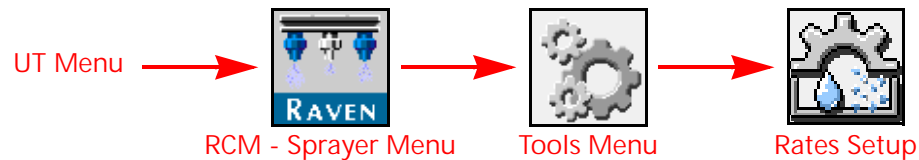

1. Open the UT Menu and select the RCM - Sprayer Menu button.
2. Select the Tools Menu softkey along the right side of the display.
3. Select the Rates Setup tab along the top of the display.
4. The following options and features are available on the Rates Setup page:

PRESET RATE VALUES

Enter non-zero rate presets to allow the equipment operator to quickly switch between user defined rates during field operations. While operating in the automatic product control mode, the rate preset buttons are displayed within the product rate tab view on the Home page.

NOTE: In manual control mode, the rate preset buttons will be replaced with the control valve \pm buttons.

PRESET PRESSURES

NOTE: Pressure presets are disabled or not available in some nozzle control modes or on any direct injection product rates.

Enter non-zero pressure presets to allow the equipment operator to quickly switch between user defined pressures during field operations. While operating in the automatic product control mode, the pressure preset buttons are displayed within the pressures tab view on the Home page.

NOTE: In manual control mode, the pressure preset will be replaced with the NCV PWM percent \pm buttons.

RATE SELECTION

Use the drop-down option to select between the following options:

Predefined or Rx (Prescription). Use predefined application rate values or a prescription (Rx) map to input rate changes.

UT Rate Entry. Use this setting when not using Rx or Predefined application rate maps. Input the rate directly into the field.

DISPLAY SMOOTHING

The Display Smoothing feature allows the system to smooth the actual rate display during operation. When enabled, the actual rate display will show the target rate as long as the actual rate is within $\pm 10\%$ of the target rate. The actual rate will be displayed if the rate controller does not reach the control deadband within 10 seconds.

RATIO RATE

NOTE: The ratio rate feature is available only when direct injection is detected.

Enable the Ratio Rate feature to maintain a ratio of direct injection flow into the carrier flow based on the carrier flow meter reading. When the ratio rate is disabled, the direct injection flow is based upon the target application rate of the direct injection product, independent of the carrier target application rate.

NOTE: The Ratio Rate option should only be checked when the injected chemical label specifically calls out a volume per volume ratio of chemical to carrier (e.g. oz/gal or mL/L) instead of volume of chemical per applied area (e.g. oz/acre or mL/Ha).

FEATURE UNLOCKS TAB

The Feature Unlocks tab allows the operator to review the status of optional features of the nozzle control system or activate additional features using an activation key. Unlocked features are visible on the Feature Unlocks page.

NOTE: Contact a local Raven dealer for additional information regarding available features or to acquire activation keys.

ENTER ACTIVATION KEYS

To access the Feature Unlocks tab:

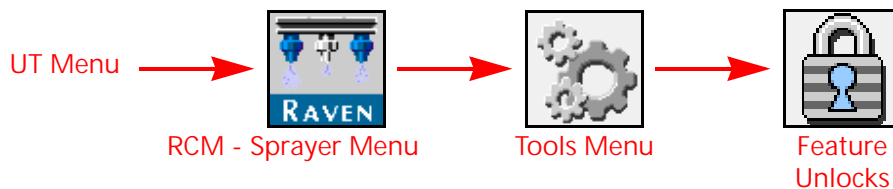

1. Open the UT Menu and select the RCM - Sprayer Menu button.
2. Select the Tools Menu softkey along the right side of the display.
3. Select the Feature Unlocks tab along the top of the page.
4. Touch the Activation Key field and use the on-screen keyboard to enter the code purchased from your local Raven dealer.

NOTE: Also displays features already unlocked for use with the RCM - Sprayer system.

The precision farming setup allows the user to modify configurations that may not be available through the universal terminal.

IMPORTANT: Depending upon the universal terminal, the following settings and options may or may not affect actual application or system operation.

To adjust precision farming settings after performing a machine configuration:

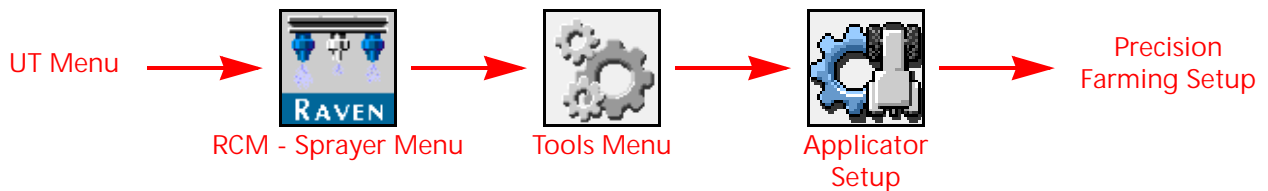

1. Open the UT Menu and select the RCM - Sprayer Menu button.
2. Select the Tools Menu softkey along the right side of the display.
3. Select the Applicator Setup tab along the top of the display.
4. Select the Precision Farming Setup button. Review the instructions on screen. To proceed with the wizard, touch the Next button. The Product Delay Setup page will be displayed.

NOTE: Touch the Previous button to return to previous pages in the Precision Farming Wizard as needed.

5. Enter a Product Delay value for each product control channel. The Product Delay value is the time required for the product control system to adjust when changing rate zones using a prescription map.

FIGURE 1. Setup Product Delay



- Press Next. The Section Offsets page is displayed.

FIGURE 2. Section Offsets

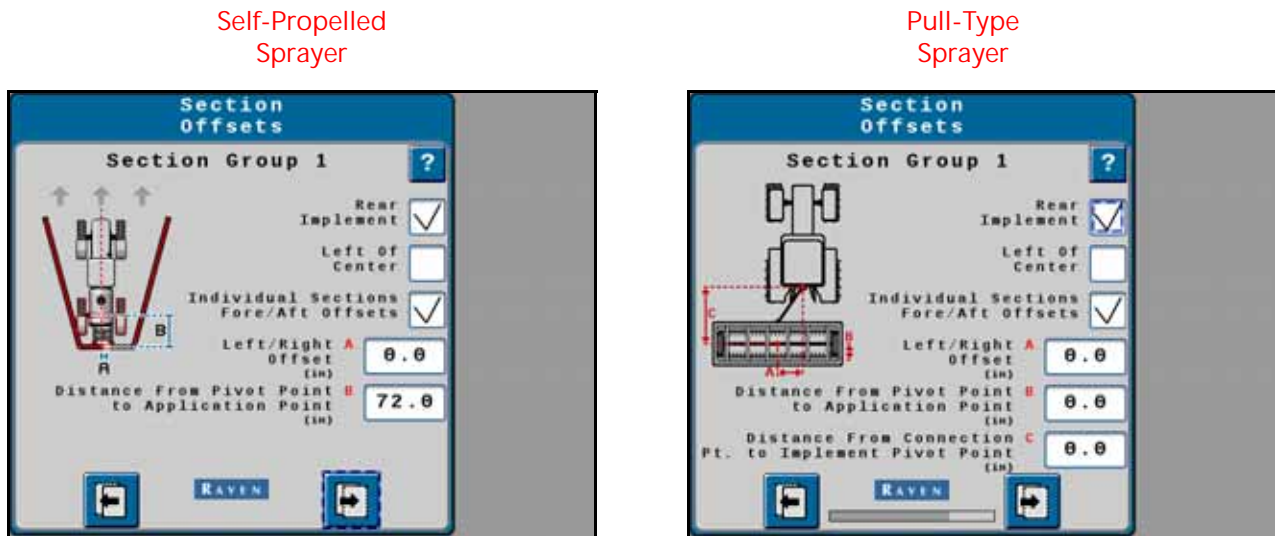

- Enable the Left of Center option if the boom is offset to the left of the centerline of the sprayer. If the boom is centered on the sprayer or is offset to the right, leave the Left of Center option unchecked.
- If boom section spray tips are offset from the center section, enable the Individual Section Fore/Aft Offsets to allow Section Fore/Aft Offsets to be configured for each section along the spray boom.

NOTE: This feature is not supported by all task controllers.

It is recommended to enter the "B" measurement (distance from the pivot point to the center of the spray boom) before enabling the Individual Section Fore/Aft option. Initially, the individual section offsets should be equal to the B value.

A negative fore/aft value indicates that the section is behind the machine pivot point with respect to the direction of forward vehicle travel. Increase the fore/aft value to move individual sections forward. Decrease values to move individual sections rearward.

- Measure the distance from the center of the boom to the centerline of the sprayer. Enter the measurement in the A field in inches [centimeters].

NOTE: The value entered for the A distance must be measured perpendicular to the direction of vehicle travel.

- Enable the Rear Implement option if the boom is mounted over or behind the rear axle of the machine or the pivot point of a pull-type sprayer. If the boom is mounted at the front of the sprayer, or in front of the rear axle, leave the Rear Implement option unchecked.
- Measure the distance from the sprayer pivot point to the boom. For example, the center of the sprayer axle or the rear axle on a self-propelled sprayer to the boom. Enter the measurement in the B field in inches [centimeters].

NOTE: The value entered for the B distance must be measured parallel with the direction of vehicle travel.

- When configuring the system for a pull-type sprayer, measure the distance from the pivot point to the implement hitch. Enter the measurement in the C field in inches [centimeters].

NOTE: The value entered for the C distance must be measured parallel with the direction of vehicle travel.

13. Press Next.

- If the option for individual fore/aft values was enabled, proceed to step 14 to continue with the system calibration.
- If the individual fore/aft values is disabled, skip to step 16.

14. Set the fore/aft values for individual sections.

FIGURE 3. Setup Product Delay

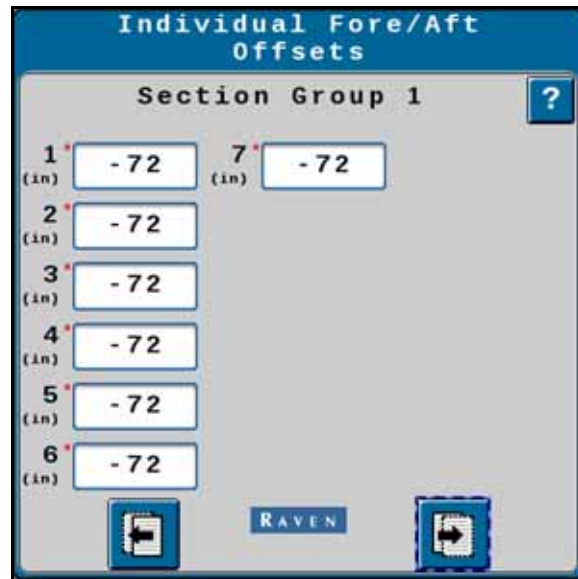

15. Select the Next button.

16. If desired, enter values for Section Group On/Off Times. Section Group On/Off Times will open or close sections prior to reaching the target area. These values can help make up for delays due to system plumbing.

FIGURE 4. Section Turn On/Off Times

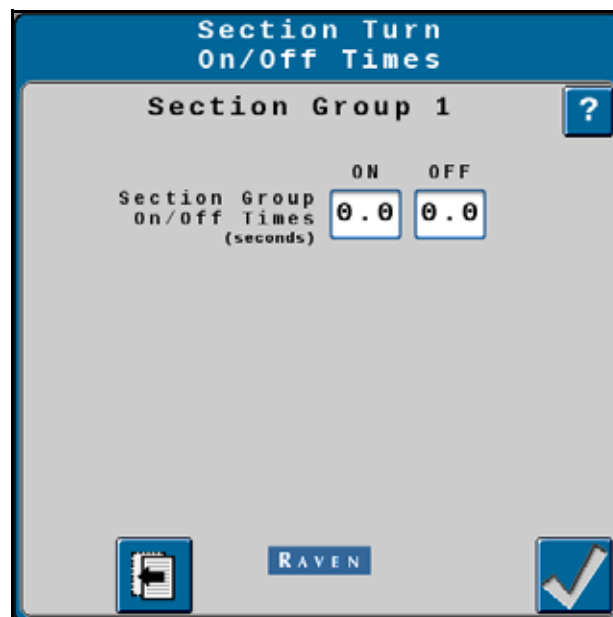

17. Press the Accept button to complete the Precision Farming Wizard.

OPERATION CHECKLIST



WARNING

Chemical will be discharged during the operation checklist procedure. Be sure the boom is fully unfolded and in a location safe for chemicals to be dispensed.

To begin applying product using the Rate Control Module (RCM) - Sprayer control system:

1. Verify the proper control mode (Standard, Bypass, On/Off, High Flow, Tiered Nozzle, or Variable Pressure) is enabled.
2. Verify the tip size selection for the nozzle control system.
3. Verify the product type (Water-Based or Fertilizer). Refer to the *Product Type* section on page 31.
4. Set the desired target rate and pressure. Refer to the *Status and Control Inputs* section on page 53 for additional information.

NOTE: Target pressure is not available when operating in the Variable Pressure, Tiered Nozzle, ON/OFF, or Bypass modes.

5. If the machine is equipped with a master tank valve, verify the tank valve is open to direct flow to the carrier pump.
6. If the machine is equipped with a toggle switch to engage the pump, it may be necessary to engage the switch before using the Engage Pump softkey on the RCM - Sprayer screen.
7. Select the main product status button to toggle the product pump on. Refer to the (4) *Main Product* section on page 53 for additional information.
8. Prior to field operation, ensure all spray boom sections are primed with new product and all air and residual or old product has been exhausted from the boom.
 - Excess air in the boom may cause unstable control, resulting in mis-application.
 - Excess residual or old product can result in misapplication and "W" pattern application until the correct mix of new product is in all boom sections.
9. Use the Boom Prime, or the Recirculation if equipped, feature to prime the boom with new product. Refer to *Boom Recirculation* section on page 40 and the *Automated Boom Prime* section on page 57 for more information.
10. Set the product rate mode to Auto for field operations and begin driving.

NOTE: If testing the system outside of field operations or while stationary, set the Self Test Speed to the typical field operation speed or change the product rate mode to Manual and adjust the control valve setting to adjust system output.

11. Toggle the equipment master switch to the on position.

UNIVERSAL TERMINAL DEFINITIONS

To access the RCM - Sprayer home screen, select the RCM - Sprayer Menu button on the UT Menu.

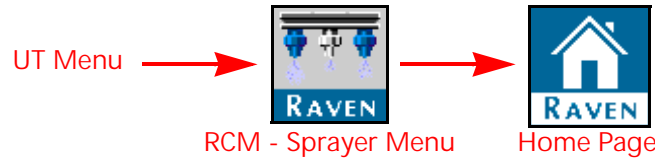
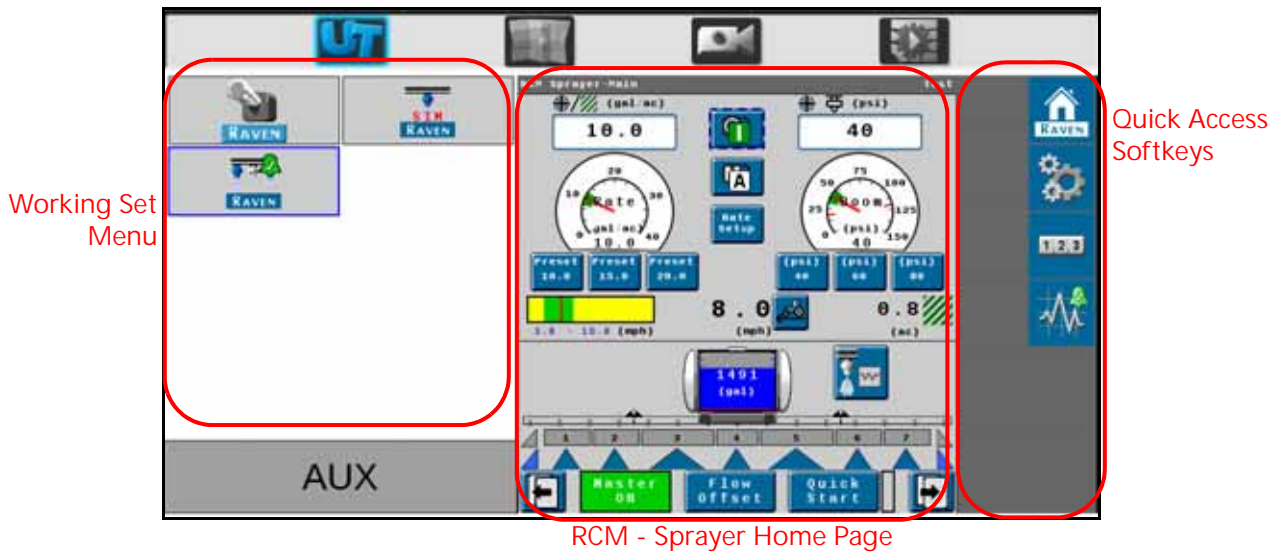

FIGURE 1. Home Page Raven



UT WORKING SET MENU

The UT Working Set menu displays systems and components detected on the ISOBUS. Use the Working Set menu to access these systems, including the RCM - Sprayer working set, and allows the operator to operate the system and monitor performance of system operation.

NOTE: The UT working set menu may be shown differently on various Universal Terminal displays. Refer to the specific display instructions for additional assistance with using the display or finding and using ISOBUS systems, components, and features.

QUICK ACCESS SOFTKEYS

The softkeys displayed along the right side of the RCM - Sprayer working set allow quick access to commonly used features, calibration settings, and options. Review the following sections for additional information about the RCM - Sprayer softkeys:

HOME

Touch the Home softkey to quickly return to the Home page and access the primary RCM - Sprayer operation information. Use these pages to monitor the Hawkeye® 2 system during field operations.



Home

TOOLS

Select the Tools Menu softkey to access the calibration prompts. See Chapter 4, *System Setup*, for additional assistance with system calibration, features, and settings.

Tools
Menu

TOTALS

Select Totals softkey to view the distance, volume, and area tallies calculated by the RCM - Sprayer ECU. See Chapter 7, *Totals*, for additional assistance with the Totals features.



Totals

The totals button provides options to access a Current Totals, Device totals, and Distance totals tabs.



DIAGNOSTICS

Select Diagnostics to access system information, tests, and diagnostic trouble codes (DTCs). Refer to , *NCV Diagnostics*, for additional assistance with the Hawkeye® 2 NCV diagnostics prompts.



Diagnostics

The DTC Status indicator is displayed on the Diagnostics softkey and provides a visual indicator of the system status during field applications. The status indicator provides the following display states:

	OK. The system status is normal and no alarm conditions are currently present.
	Caution. A minor alarm condition has been detected. The control system is operating normally, however, the system has detected that a condition exists which could impact the current application.
	Critical. A critical system condition has been encountered. The control system is not responding as expected and the operator should cease application and troubleshoot the issue before resuming operations. The system will not apply in this state

Refer to Chapter 9, *Troubleshooting*, for additional assistance with diagnostic trouble codes and using the DTC list.

TRANSFER UNIVERSAL TERMINALS

The Transfer UT softkey will be displayed if more than one UT is detected on the ISOBUS. Use this button to switch the RCM - Sprayer working set menu to an alternate UT at any time.



Transfer UT

If the working set is not available on the desired UT, check the other displays and use the Transfer UT softkey to transfer the RCM - Sprayer working set.



RCM - SPRAYER HOME PAGE FEATURES

FIGURE 2. Home Page Displays w/ Injection or Advanced Mode Activated

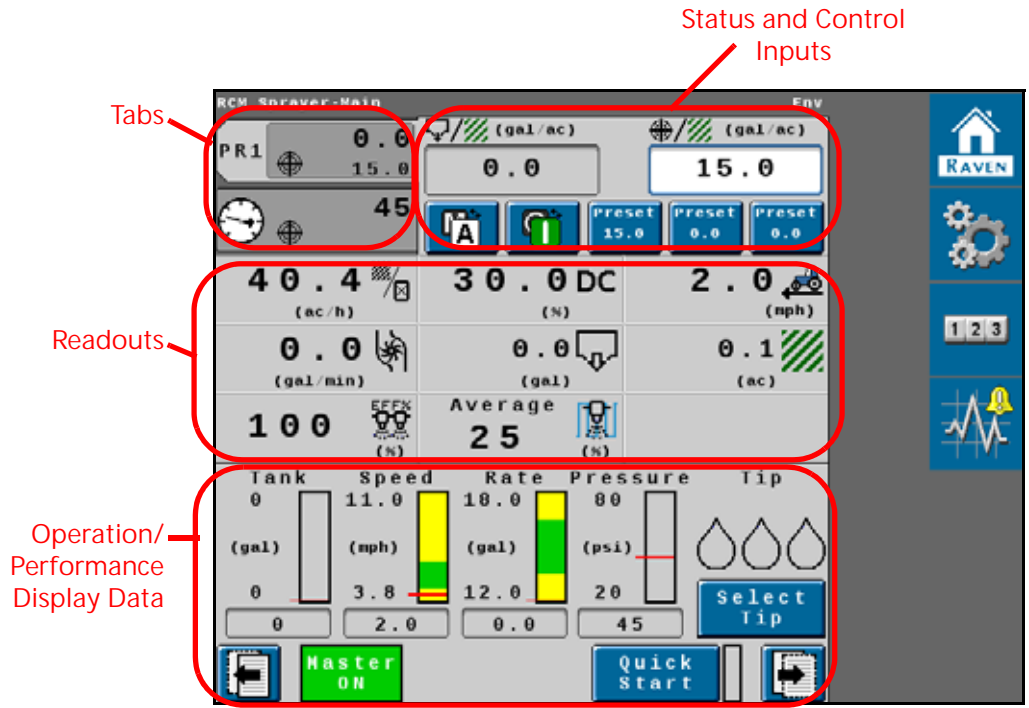
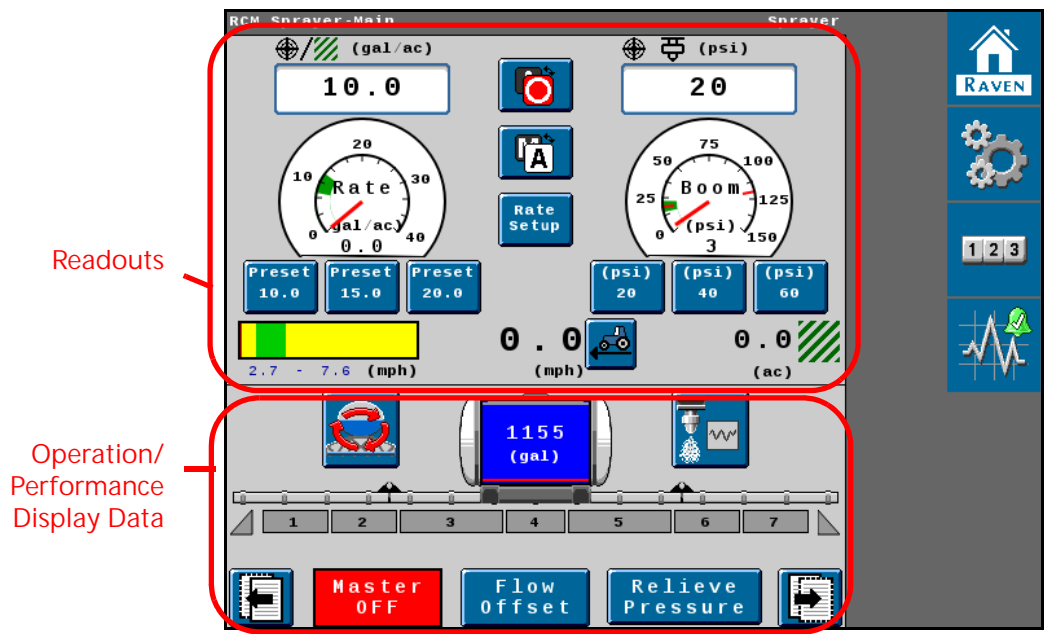

FIGURE 3. Home Page Displays w/o Injection or Basic View



Depending upon the mode and system options, the following display areas, information prompts, and features may be accessible via the RCM - Sprayer home page:

TABS

Tab views are available on the RCM - Sprayer home page. Tabs allow the operator to quickly toggle between different information displays and user configurable readouts during field operations.

The UT offers tabs for each product controlled by the RCM - Sprayer system as well as a tab to assist with monitoring system pressure information.

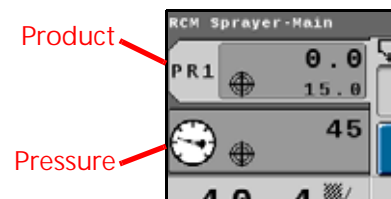

NOTE: Review the *Readout Descriptions* section on page 33 for additional assistance with the available readouts.

STATUS AND CONTROL INPUTS

The upper, right corner of the Home page provides the operator with access to the following important status displays and system control features:

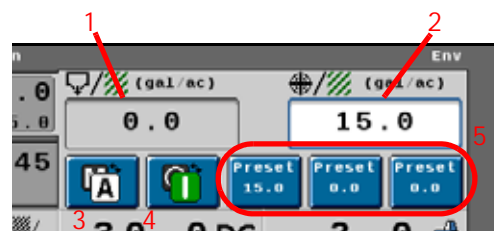

(1) Actual Rate/Pressure. Depending upon the tab selected, the actual rate or actual pressure is displayed in this area.

(2) Target Rate/Pressure. Depending upon the tab selected, the target rate or target pressure is displayed in this area. Touch this field to enter a new target rate or pressure as needed during field applications.

NOTE: Target pressure is not available for VP, On/Off, Tiered Nozzle, and Bypass modes.

(3) Product Rate Control Mode (M/A). Touch the rate control mode button to toggle the selected product between automatic and manual control modes.

When the system is toggled to the manual control mode, the preset buttons will be replaced with \pm bump buttons. Review the (5) *Presets* section on page 53 and the (5) *Manual Control* section on page 54.

Product Rate Mode



Product Status



(4) Main Product. The status of the product is displayed on the upper portion of the Home page. Select the product status button to toggle the main product on or off during field applications.

NOTE: Both the master switch and the product must be toggled on to apply product.

If the machine has an additional switch to open a master tank valve and/or turn on the main product pump, ensure the machine switch is turned on before the on-screen main product button is toggled on and that the master switch is toggled on to prevent pressure spikes in the system when starting application. See the *Master Switch Status* section on page 54 for additional assistance with the master switch status display if available.

(5) Presets. Rate or pressure preset buttons are shown toward the upper, right corner of the display below the target rate or target pressure fields.

Touch the rate or pressure preset buttons to manually toggle between preset rates or pressures.

Refer to the *Rates Setup Tab* section on page 43 for additional assistance with the rate and pressure preset values.

Presets

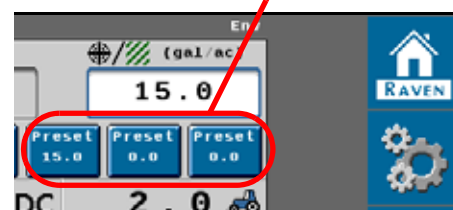

NOTE: Double tap the rate or pressure tab in Advanced display mode or press the Rate Setup button in Basic display mode to quickly access the Rates Setup page and change the set preset values.

(5) Manual Control. When the system is toggled to the manual control mode, the preset buttons are replaced with ± buttons.

- The ± buttons on the Rates tab manually increase or decrease the main product pump output.

NOTE: The main product pump manual control softkeys are replaced by the injection pump manual control softkeys when the injection pump product is selected.

- The ± buttons on the Pressure tab increase or decrease the NCV PWM duty cycle.

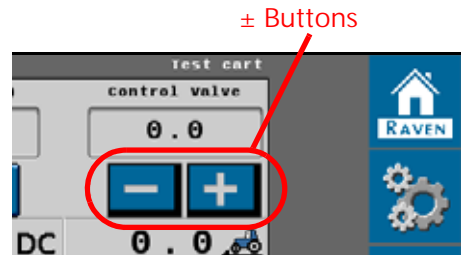

The system will continue to monitor and display the actual application rate on the home screen.

READOUTS

The readouts area of the RCM - Sprayer Home page is user configurable to allow the operator to set up the information to be displayed for each product or pressure tab. Review the *Display Setup Menu* section on page 32 for additional assistance with customizing the information displayed on each tab and for details about the available readouts.

PRESSURE GAUGE

When the RCM - Sprayer product is selected, the pressure gauge provides a visual representation of the actual boom pressure and displays the allowable pressure deadband during field applications.

NOTE: When an injection product is selected, the pressure gauge displays the pressure at the injection pump.

RCM - SPRAYER LOWER HOME SCREEN

The lower portion of the home screen provides on-screen indicators for switch status and remaining tank volume. Refer to the following sections for additional information regarding the information provided in this area of the home display.

MASTER SWITCH STATUS

NOTE: If a Raven ISOBUS switch box, or another compatible master switch, is connected to the Hawkeye® 2 nozzle control system, the current status of the master switch will be displayed toward the lower, left corner of the screen. This is a display only and the physical switch must be used to toggle the system master on or off during field applications.

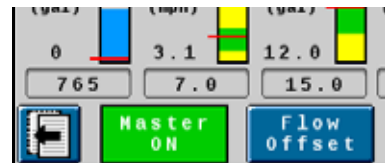

TANK VOLUME INDICATOR

The system provides a calculated volume of product remaining in the tank as a tank indicator in the application information area. Select this indicator to access the Tank Fill Config prompt.

NOTE: A tank capacity value must be entered to allow the tank volume indicator to display the tank level.

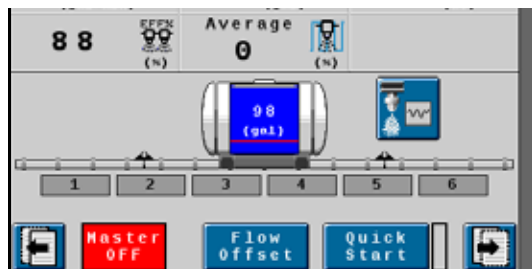

SECTION STATUS DISPLAY

The Hawkeye® 2 system provides the status of each configured section on the home display.

Section On/NCVs On. The section is on and all NCVs are actively applying.

Section On/Mixed NCV Status. The section is enabled and at least 1 NCV assigned to the section is applying. The task controller may automatically control NCVs as needed to cover field area.

Section On/NCVs Off. The section is enabled and ready for application. The task controller may automatically turn on NCVs assigned to this section.

Flow Offset Enabled. A flow offset is active in that section.

Section Off. the section is manually disabled. NCVs assigned to this section cannot be enabled or turned on by the task controller.

NCV FLOW OFFSET %

The Flow Offset feature allows a limited number of NCVs to provide additional flow. For example, NCVs in line with the sprayer wheel tracks may need increased flow to ensure complete coverage. The NCV Flow Offset percentage value sets how much the offset NCV will deviate from nominal flow.

Flow offsets may be $\pm 50\%$ and the machine operator may enter two preset profiles of four NCVs and both preset profiles may be active at the same time.

NOTE: When offset profiles are active, the triangle for the affected section will display purple and the Offset button will display green.

ON-SCREEN MANUAL SECTION CONTROL

NOTE: The on-screen manual section controls will only be displayed if an optional Raven ISO Switch Box, or another compatible switch interface, is not available via the ISOBUS. If a switch box is detected, use the switch box to control boom sections or to enable the override feature. Review the Raven ISOBUS Switch Box Operation Guide for additional assistance with the Raven ISO Switch Box.

To use the on-screen switch box:

1. Touch the Switch Box button at the bottom of the Home page. The on screen section buttons are displayed.
2. Use the numbered section buttons to toggle individual sections as desired or use the All On button to quickly toggle all sections back on.
3. Touch the Return button at the bottom of the page to return to the standard Home page display.

ON-SCREEN FENCE ROW STATUS AND CONTROL

If on-screen fence row control is enabled during the initial calibration wizard, the left and right fence row controls will be available on the main screen.



Status of fence rows are displayed in the Section Status area. Review the *Section Status Display* section on page 55.

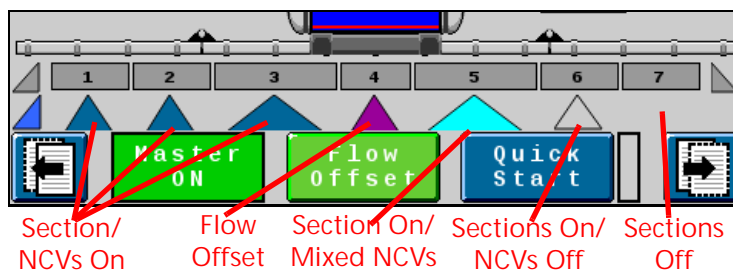

QUICK START

Use the Quick Start button at the bottom of the RCM - Sprayer home screen to override all sections for the configured override time. After the override time expires, the task controller will resume automatic operations based upon previous section coverage.

Refer to the *Quick Start Seconds* section on page 39 for additional assistance with the override seconds setting if necessary.

PERFORMANCE DATA DISPLAY

Toggle to the performance data display to monitor various system performance statistics and recommended operation ranges in one view.

This view displays the user defined tank volume and volume remaining in the tank, the recommended speed range and current speed, current application rate and off rate limits, current pressure and allowable pressure range, as well as the droplet size settings and monitoring options previously entered by the operator.

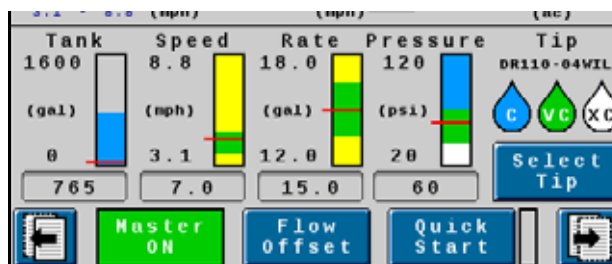

Tank. Displays current tank level (blue level and bottom value), overall tank capacity, and low tank alarm set-point (red line). Values change when apply, filling, or when entered in the Tank Fill Settings menu.

Speed. Displays current speed (red line and bottom value) and recommended speed range (green). Overall range is 0 - 30 mph [0 - 48 km/h]. Values change when applying or when target rate, target pressure, tip size, or operating mode are adjusted.

Rate. Displays current application rate (red line and bottom value) and Off Rate Alarm % range values (e.g., +/- 20%). Values change when applying or when actual rate, target rate, or Off Rate Alarm % values are adjusted.

Pressure. Displays current application pressure (red line and bottom value), minimum and maximum pressure range, and color scale for droplet size range information entered in the Select Tip menu.

Tip. Displays user-entered tip name and any droplet size information from the tip that was selected in the Select Tip menu.

NOTE: The pressure color scale, tip name, and droplet size information options are not available in High Flow NCV Control Mode.

AUTOMATED BOOM PRIME



 **WARNING**

Chemical will be discharged during the boom prime procedure. Be sure the boom is fully unfolded and in a location safe for chemicals to be dispensed.

The Automated Boom Prime function page can also be quickly accessed by Rates Setup page. Find the Rates Setup page in the Product Rate Control tab.

FIGURE 4. Rates Setup Page

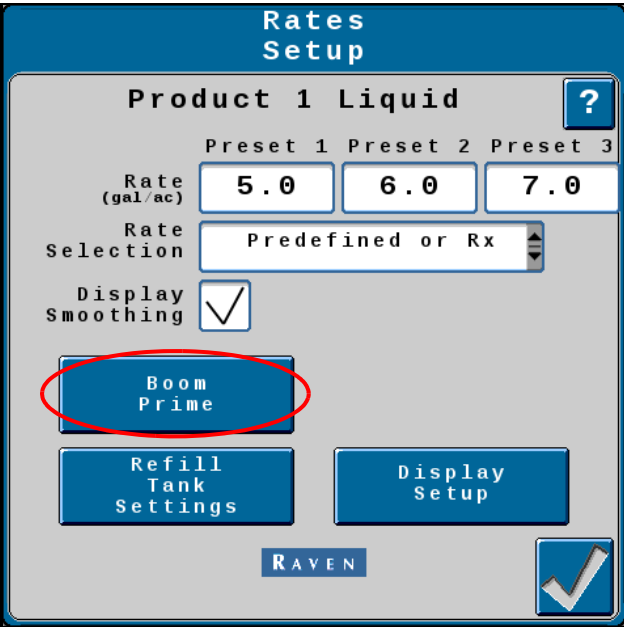

Automated Boom Prime will automatically turn on the main product pump and control valve to the set Tank Fill control valve duty cycle and each configured spray section for the assigned Auto-Operation time, starting from the outermost section and working inward, until each section has turned on once.

NOTE: Ensure the main product tank has sufficient product to fully fill the spray boom and have some visibly remaining in the tank to prevent from getting air in the pump and system plumbing. Ensure all machine valves are in the spray position. Move the machine to an area safe for the application system to spray and be fully unfolded.

1. Select Begin to enter the Boom Prime Menu.
2. Enter in the Section Auto Operation Time for each section. Sections will operate automatically in pairs from outermost to innermost sections. Auto-Operation times do not need to be equivalent for pairs, and can be adjusted up to a maximum of 180 seconds.

3. Turn on the machine master switch, and press the accept button to proceed with priming.

NOTE: Section valves and NCVs will open and product will be dispensed during this process.

FIGURE 5. Automated Boom Prime Page

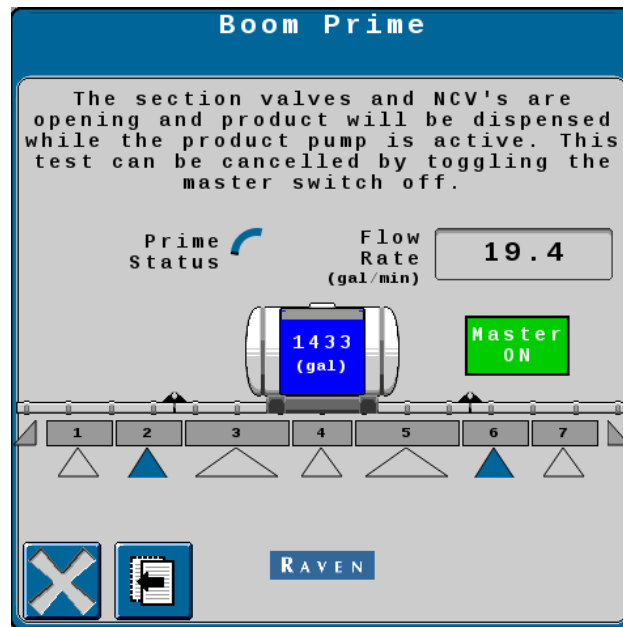

When each section has operated once, the priming process is complete. The process can be interrupted at any time by turning off the master switch, or pressing the back or exit button. By turning off the master switch or pressing the back button, you can adjust the Section Auto-Operation Times. By pressing the exit button, the test will be canceled and you will return to the Tests menu. Turn off the master switch when Priming is complete.

4. For systems equipped with chemical injection, stationary priming must be done for each product using a self-test speed in Automatic mode with all products on.
5. For systems equipped with recirculation, use the recirculation process to prime the booms.

USING TOTALS

To access the RCM - Sprayer Totals pages:

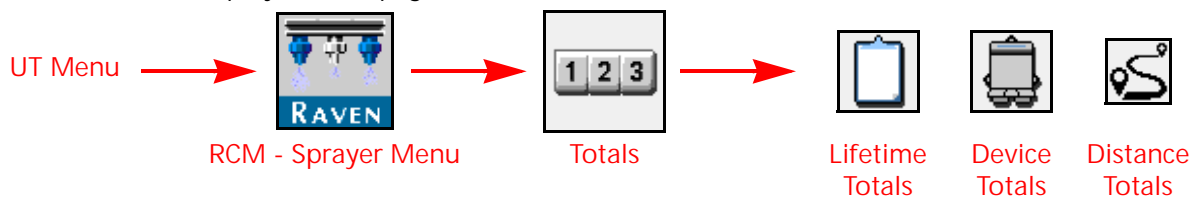

1. Open the UT Menu and select the RCM - Sprayer Menu button.
2. From the home screen, select the Totals softkey along the right side of the display. The following tally information tabs are available:

Lifetime Totals. Provides application tally information for each product control channel.

Depending upon your reporting or data needs, application tallies for each control channel may be accumulated for the day or week of operation, or may be reset after each field. This information is available to the UT (e.g. Viper 4) and can be included with the application or coverage reports.

NOTE: Each product control channel must be reset separately.

Device Totals. Displays a running tally of the operating life of the RCM - Sprayer system. This includes the runtime of the ECU, the runtime of the NCVs, and the total area covered. This tally cannot be reset by the machine operator.

Distance Totals. Provides the operator with operation information such as current equipment speed and distance traveled since the Distance Totals were last reset.

The distance registers may also be helpful when fine tuning the RCM - Sprayer system or to assist with troubleshooting procedures.

RESET A REGISTER

To reset the Lifetime Totals or Distance Totals register:

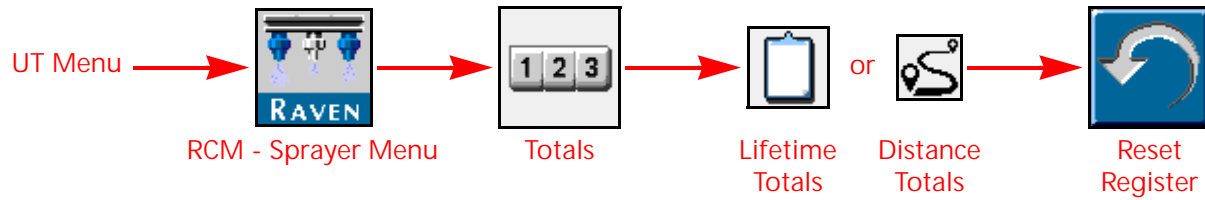

1. Open the UT Menu and select the RCM - Sprayer Menu button.
2. From the home screen, select the Totals softkey along the right side of the display.
3. Select the Lifetime Totals and the desired product channel or Distance totals tab along the top of the page.

NOTE: The Device Totals cannot be reset by the machine operator.

4. Select the Reset button to reset all the Totals displayed on the page.
5. Accept the confirmation prompt to proceed with resetting the selected registers.
6. Repeat the above process to reset other Totals as desired.

System and NCV information, diagnostics, and tests are accessible via the Diagnostics softkey displayed along the right side of the page.

To access System or NCV Diagnostics:

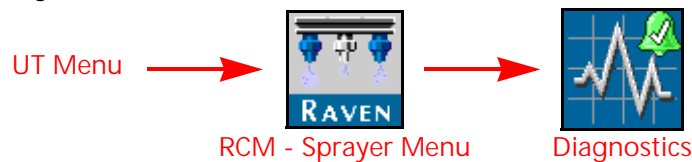

1. Open the UT Menu and select the RCM - Sprayer Menu button.
2. Select the Diagnostics softkey.

Refer to the following sections for additional system or NCV diagnostics information:

- *System Diagnostics* section on page 61
- *NCV Diagnostics* section on page 83
- *NCV Updates* section on page 85

SYSTEM DIAGNOSTICS

SYSTEM INFORMATION

To review information about the RCM - Sprayer:

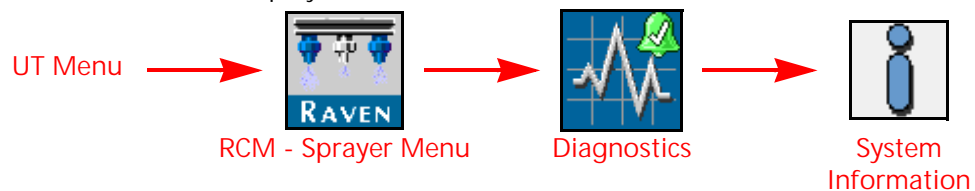

1. Open the UT Menu and select the RCM - Sprayer Menu button.
2. Select the Diagnostics softkey along the right side of the page.
3. Select the System Information button. The following information is displayed on the page:

Hardware/Software. Displays hardware and software information for the ECU.

Delivery System. Displays application information for the product when active and applying.

System Voltages. Displays voltage and current information for the ECU and attached sensors.

Speed Source. Displays any detected speed sources and options to select. “Auto” is recommended for most applications.

Switch Box. Displays detected section control switch status information.

Section Status. Displays section driver status information.

Working Parameters. Displays the implement width, current speed, speed source, speed source ISO name, and address.

Pressure Sensors. Displays voltages and pressure information for each pressure sensor.

Task Totals. Displays the area covered and volume applied for the current task.

Inertial Sensors. Displays the detected ECU yaw rate and downward direction.

TESTS

Run diagnostic tests to check system operation, for help locating components requiring service or replacement, and other information to assist with keeping the Hawkeye® 2 working at maximum efficiency.

To access available tests:

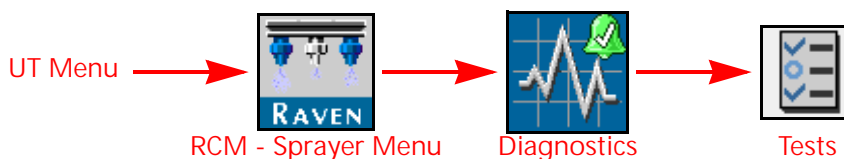

1. Open the UT Menu and select the RCM - Sprayer Menu button.
2. Select the Diagnostics softkey.
3. Select the Tests Tab at the top of the page. The following diagnostic tests are available:

NCV Communication Test. Scans the NCV CANbus communication and assists in locating where issues may be present. Boom graphics show indexing order from leftmost to rightmost NCVs. No Communication After and Communication Resumes At values will be shown. When only a few NCVs are noted, inspect nearby NCVs, connections, pins, and cabling for corrosion, visible damage, or pinching between those NCVs. In some instances, splices or wiring may be damaged underneath cable sheathing. Inspect those items along with fuses, 19-pin connections, and terminators when large sections of NCVs are not communicating.

NOTE: Refer to Chapter 9, *Troubleshooting*, for additional assistance with NCV

Controller Statistics. This process allows you to view detailed product controller performance and health statistics including Boom Pressure, Target Pressure, Pump Control Effort, Actual Flow per Area, and Target Flow per area over a user-defined amount of time. You may start the test immediately or press delayed start to start the test later. The test will record up to two parameters, and provide a graph of performance.

NCV Statistics. Allows access to view NCV statistics including Driver Temperature, Logic Temperature, Open Hold Current, Powered Time, and HC Voltage Minimum. Press Start Data Visualization to generate an on-screen graph of each NCV. Arrow over to see data for a specific NCV.

NCV Updates. Scans all NCVs for potential updates. If an update is detected, an option will be given to update the software. This test requires the engine to be running and the NCV bus to be communicating and properly terminated.

Calibrate NCVS. This test will allow you to recalibrate your NCVs. This process is recommended after replacing one or more NCVs.

Reboot Product Controller. Allows you to reboot the product controller ECU. This will reset the controller and re-initialize communication with the CANbus without resetting controller parameters.

Boom Pressure Relief. This procedure will activate the NCVs or section valves or open the recirculation valve for 10 seconds to relieve pressure to the product tank when the product pump is turned off. System pressure may be monitored on the screen. Ensure the machine is in a safe area and the master switch is on prior to beginning this procedure.

NOTE: When recirculation is configured, Boom Pressure relief will relieve pressure to the product tank through the recirculation valve instead of dispensing product through the NCVs.

	<p style="text-align: center;">⚠ CAUTION</p> <p>Some residual pressure may exist in the boom or other plumbing circuits after this action is performed. Always wear proper personal protective equipment and slowly open any plumbing components when performing system maintenance.</p>
---	---

Boom Prime. This procedure will prime the boom with product by opening the section valves and NCVs. Each section valve switch must be on, and the master switch must be turned on. The product pump will turn on and product will dispense out the boom for the entered Section Auto-Operation Times, beginning from the outermost and progressing inward.

	<p style="text-align: center;">⚠ WARNING</p> <p>Chemical will be discharged during the boom prime procedure. Be sure the boom is fully unfolded and in a location safe for chemicals to be dispensed.</p>
--	--

PWM Health Test. This test analyzes the performance and control range of the PWM pump control valve when equipped.

During the test, the system will automatically increase PWM duty cycle and monitor system boom pressure and provide the control range and system output parameters. The minimum and maximum control effort values will be calculated, and overall health will be determined. For best control, the PWM control range should be greater than 20% and the graphed line should not have large steps where the displayed pressure is constant during the test.

NOTE: A narrow overall range, large steps in control, or high response hysteresis (significant differences between increasing and decreasing duty cycle performance) may result in erratic system performance. Consult with the sprayer manufacturer if the test repeatedly shows these types of errors.

Demonstration Mode. Allows you to simulate typical operating pressure and system flow. This is only intended for bench-top simulation and not for use on a machine while actively spraying. Failure to comply may result in product being dispensed as the control valve may be actuated based on the simulation conditions.

Service Mode. Allows access to enhanced diagnostics and features.

PERFORM THE PWM HEALTH TEST

	<p style="text-align: center;">WARNING</p> <p>Chemical will be discharged during the test procedure. Be sure the boom is fully unfolded and in a location safe for chemicals to be dispensed.</p>
---	--

NOTE: For this test, park the sprayer in a safe area. The test can be run without turning on the master switch and spraying product for systems that do not have injection systems installed. Product should be in the tank, and the sparge should be closed to prevent system flow losses. Engine RPM should be at least 1800. Ensure system plumbing is not pinched and strainers are clean. If the system has a check valve for direct injection, the system must spray product to determine valve performance. Park the system in a safe area and turn on master switch and all boom switches while performing this test.

To perform the test:

1. Ensure there is product in the main product tank.
2. Close all open agitation or sparge lines.
3. Ensure all machine control valves are directed to the spray position.
4. Press Begin under the PWM Health test.
5. Set engine RPM to approximately 1800 during the test.

NOTE: If the test cancels due to system over-pressure, you may need to slightly decrease engine RPM and run the test again.

6. Turn on the system master spray switch.
7. Press the Next button to start the test.

The test will start running the product PWM control valve at the minimum duty cycle, up to the maximum duty cycle, and back to the minimum. The system flow and pressure will change while this test is happening and product will spray out of the nozzles.

NOTE: Press the Cancel button to stop the test at any time.

8. Once the test is complete, the PWM valve will turn off.
9. Turn off the master spray switch and return the engine RPM to idle. If the PWM cartridge has sufficient range, a green check mark will display on the page.
10. Press Apply Suggested Settings to accept the suggested changes to the PWM range or Ignore to keep the previous values.
11. Press the Accept button to return to the previous page.

PMW HEALTH TEST - EXAMPLE RESULTS

Good Control Performance. Example of pwm control valve performing well with good response hysteresis. Curves do not have significant areas of flat spots, and go over a large portion of the Control Effort Duty Cycle % range.

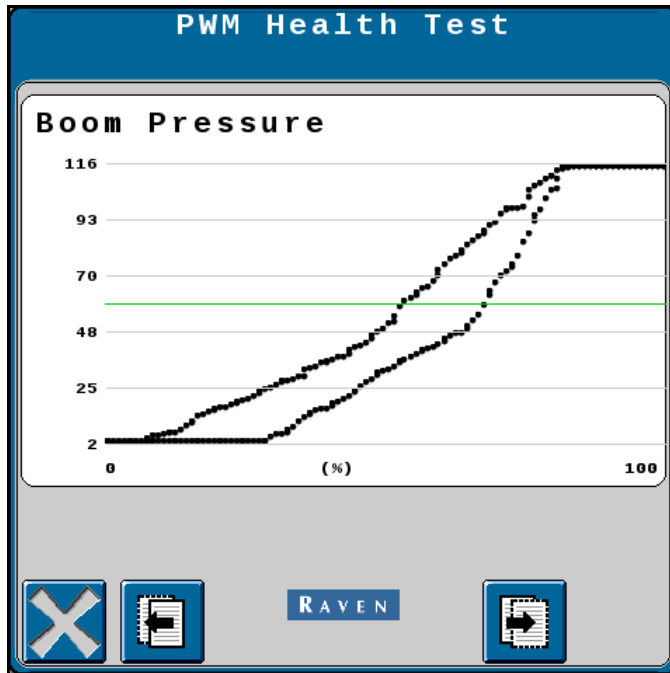

Good Control Range. Example of pwm valve having good overall control range and a large difference (>20% overall range) between minimum and maximum Control Effort Duty Cycle %. Apply suggested changes to optimize control range for the system.

PWM Health Test

A summary from the PWM health test is shown below.

Minimum Control Effort (%)

Maximum Control Effort (%)

Overall Health

Apply Suggested Settings

Consider adjusting min and max PWM settings to be similar to the values reported by this test. Press the apply button to do this automatically.

Poor Performance - Steps in Control. Example of poorly performing pwm control valve. Curves have large control steps, which will result in unresponsive control and poor system performance. PWM control valve may need to be cleaned or replaced.

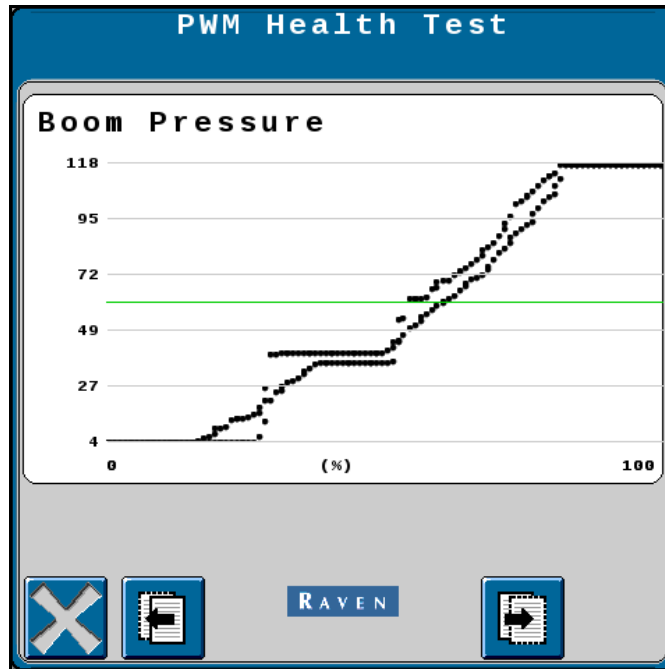

Poor Performance - Narrow Control Range. Example of very narrow pwm valve control range. Pressure reaches maximum in a very narrow Control Effort Duty Cycle % range (<20% overall range). Target Rate, Pressure, Speed, and Tip selection must be carefully chosen to ensure control is adequate. Increasing agitation may help in some cases if possible.

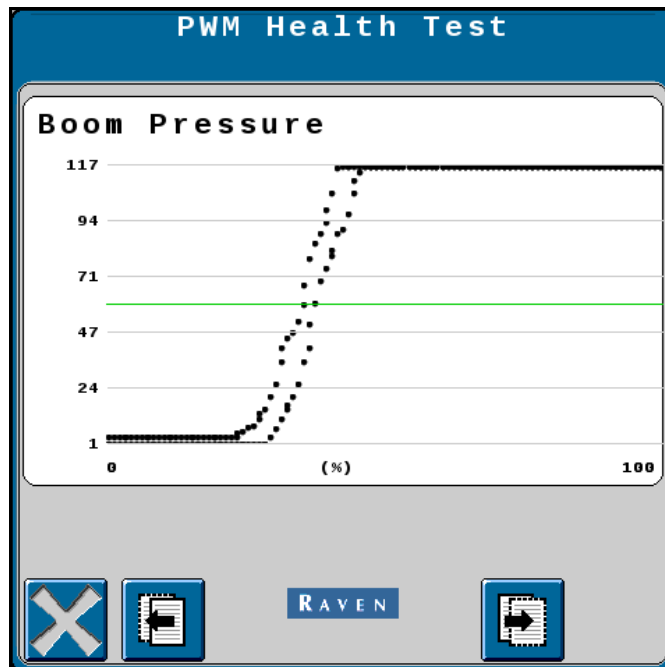

Poor Performance - Narrow Control Range. Example of very narrow pwm valve control range. Pressure reaches maximum in a very narrow Control Effort Duty Cycle % range (<20% overall range).

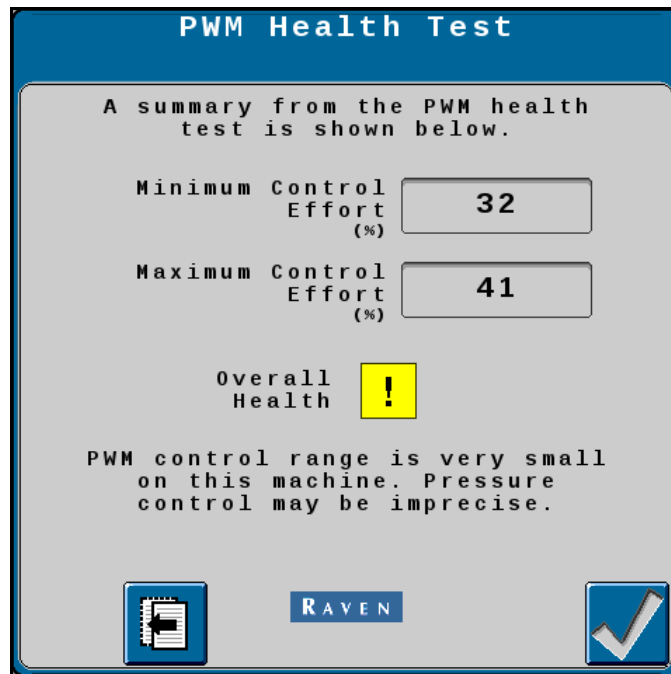

DIAGNOSTIC TROUBLE CODES (DTCs)

Displays active and inactive diagnostic trouble codes and provides the ability to clear inactive codes:

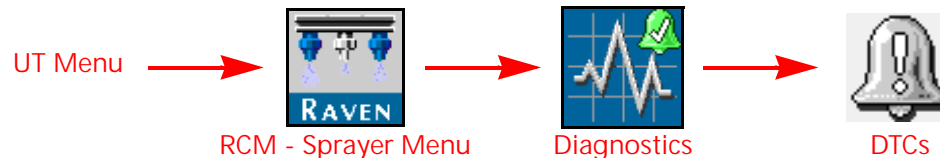

1. Open the UT Menu and select the RCM - Sprayer Menu button.
2. Select the Diagnostics softkey along the right side of the page.
3. Select the Diagnostic Trouble Codes (DTCs) tab.
 - Current trouble codes are displayed in the Active table. The DTC Identification number and occurrence count is listed.
 - Resolved trouble codes are displayed in the Inactive table. The DTC Identification number and occurrence count is listed.
4. Use the up and down arrows to scroll through the list of trouble codes. A description of the highlighted code is shown below each table.
5. If desired, press the Clear button to erase all the trouble codes listed in the Inactive table.

The following trouble codes may be displayed by the control system and should help the operator to identify and correct issues with system during field operations:

NOTE: Before taking any of the following Recommended Actions, it is suggested to cycle machine power, reboot the controller, or check ECU or boom wiring for damage, as these are common remedies and can potentially solve several issues. If none of the following Recommended Actions solve the issue(s), it is recommended to replace the RCM-S ECU or NCV(s) affected.

Code ID	Description	Recommended Actions
4985	.13 Yaw sensor calibration error	<ul style="list-style-type: none"> Park machine on level ground and disable any boom height controls. Go to <i>Tools -> System Settings -> User Settings -> Calibrate Turn Compensation</i> and verify the detected orientation is accurate, and ensure Yaw Rate is not varying by +/- .5 deg/sec while the engine is running. If needed, select Redetect Orientation to recalibrate. Cycle power to RCM-S ECU by going to <i>Diagnostics -> Tests -> Reboot Product Controller</i>.
	.2 Yaw sensor erratic	
520194	.3 Supply voltage high	<ul style="list-style-type: none"> Go to <i>Diagnostics -> System Information -> System Voltages</i> drop-down and verify RCM-S ECU Power is between 8V and 16V with engine running. Cycle power to RCM-S ECU by going to <i>Diagnostics -> Tests -> Reboot Product Controller</i>. Check power and ground at RCM-S ECU connections. (Grey connector pins PWR 1 - 3, GND 4 - 6). Repair or replace as necessary. Check power and ground on chassis cable connectors. Repair or replace as necessary. Check RCM-S ECU power at fuse panel. Repair or replace as necessary. Check RCM-S ECU cables and connections for damage. Repair or replace as necessary. Check power and ground at battery terminals and connections. Repair or replace as necessary. Check machine battery and charging system. Repair or replace as necessary.
	.4 Supply voltage low	
520453	.31 FPGA error	<ul style="list-style-type: none"> Cycle power to RCM-S ECU by disconnecting and reconnecting RCM-S ECU gray connector. Update or re-load RCM-S ECU software and create a new machine profile.

Code ID		Description	Recommended Actions
520454	.31	NCV subnet offline	<ul style="list-style-type: none"> • Go to <i>Diagnostics -> Tests -> NCV Communication Test</i> and perform NCV Communication test to determine if any NCVs are communicating. • Inspect NCV lights for power. If all NCV lights are off on one or both sides, check power circuit. If all on, check NCV CAN circuits. • Cycle power to RCM-S ECU by going to <i>Diagnostics -> Tests -> Reboot Product Controller</i>. • Check power to NCV relays at RCM-S RCM-S ECU connections. (Black center connector pins 7 LT and 8 RT). Repair or replace as necessary. • Check power and ground at left and right NCV relays and connectors. Repair or replace as necessary. • Check HC power and ground on NCV boom cables (round 19-pin connector pins PWR 8, 12, 16, GND 10, 14, and 18). Repair or replace as necessary. • Check NCV power across NCV fuses. Repair or replace as necessary. • Check NCV power at fuse box panel. Repair or replace as necessary. • Check NCV chassis and boom cables and connections for damage. Repair or replace as necessary. • Check NCV chassis cable power and ground at battery. Repair or replace as necessary. • Check NCV CAN circuits at RCM-S RCM-S ECU connections (black center connector pins 11 LO and 12 HI). • Check NCV CAN circuits at boom cables (round 19-pin connector pins 4 LO and 6 HI).
523008	.13	No tip size selected	<ul style="list-style-type: none"> • Go to <i>Tools -> Applicator Setup -> Select Tip</i> and verify a tip size other than "NA" is selected for either NCV or Bypass or both, depending on mode. Select a tip size again, even if the same. • Cycle power to RCM-S ECU by going to <i>Diagnostics -> Tests -> Reboot Product Controller</i>.

Code ID		Description	Recommended Actions
523014	.13	NCV requires message	<ul style="list-style-type: none"> Go to <i>Diagnostics</i> -> <i>Diagnostic Trouble Codes</i> -> <i>NCV Errors</i> -> <i>NCV Heat Map</i> and locate the NCV(s) that are not green. Their numerical locations are labeled referencing the forward travel direction, from leftmost to rightmost NCV along the boom. Note their location for future reference and troubleshooting as necessary. Cycle power to RCM-S ECU by going to <i>Diagnostics</i> -> <i>Tests</i> -> <i>Reboot Product Controller</i>. Check NCV software by going to <i>Diagnostics</i> -> <i>Tests</i> -> <i>NCV Updates</i> to scan and update software on affected NCVs. Replace affected NCV's. Then recalibrate NCV's by going to <i>Diagnostics</i> -> <i>Tests</i> -> <i>Calibrate NCVs</i>. If necessary, check NCV software by going to <i>Diagnostics</i> -> <i>Tests</i> -> <i>NCV Updates</i> to scan and update software on affected NCV's.
523016	.31	Inconsistent nozzle control valve software version	
523017	.31	NCV programming out of date (NCV update)	
523128	.0	High NCV temperature - single	<ul style="list-style-type: none"> May result from high ambient temperature or running NCVs without flowing liquid. Allow NCVs to cool. Replace NCV and Recalibrate NCVs by going to <i>Diagnostics</i> -> <i>Tests</i> -> <i>Calibrate NCVs</i>
523129	.0	High NCV temperature - multiple	
523136	.4	NCV voltage low single	<ul style="list-style-type: none"> Check wiring, fuses, and connections before the left and right cable circuit branches. When only a few NCVs are noted, inspect nearby NCVs, connections, pins, and cabling for corrosion, visible damage, or pinching between those NCVs. In some instances, splices or wiring may be damaged underneath cable coverings. Repair or replace as necessary. Check power and ground on chassis cable connectors. Repair or replace as necessary. Check power and ground at battery terminals and connections. Repair or replace as necessary. Check machine battery and charging system. Repair or replace as necessary.
523137	.4	NCV voltage low multi	
523147	.13	Switch box not detected	<ul style="list-style-type: none"> Check power and CAN cabling and connections to switch box. Repair or replace if necessary. Edit existing profile or create a new machine profile as required. Cycle system power.
523151	.31	Switch box has gone offline	

Code ID		Description	Recommended Actions
523076	.31	NCV offline - single	<ul style="list-style-type: none"> Go to <i>Diagnostics</i> -> <i>Diagnostic Trouble Codes</i> -> <i>NCV Errors</i> -> <i>NCV Heat Map</i> and locate the NCV(s) that are not green. Their numerical locations are labeled referencing the forward travel direction, from leftmost to rightmost NCV along the boom. Note their location for future reference and troubleshooting as necessary. Go to <i>Diagnostics</i> -> <i>Tests</i> -> <i>NCV Communication Test</i>. Displayed NCVs are numbered on screen from left to right. These are referenced from the left side of the machine, facing the normal forward direction of travel. If No CAN Error Detected is displayed, that means that the test has found no detectable communication errors. Left, right, and tip-to-tip latency times will be displayed. If an error occurs, note the "No Communication After NCV" number, and the "Communication Resumes At NCV" number. The issue is likely between, and possibly includes, these NCVs. Inspect NCVs on the boom, wiring, connections, or fuses related to the circuit between and including these NCVs. If there is no communication after the #1 NCV, there may be a power loss between the battery connection and the NCV cable connections, or a CAN communication problem between the RCM - Sprayer RCM-S ECU and the NCV cable connections. Inspect wiring, fuses, and connections before the left and right cable circuit branches. When only a few NCVs are noted, inspect nearby NCVs, connections, pins, and cabling for corrosion, visible damage, or pinching between those NCVs. In some instances, splices or wiring may be damaged underneath cable coverings. When large sections of NCVs are not communicating, inspect those items along with fuses and large electrical connections. If intermittent power to the NCVs is the cause of the issue, or if NCVs are disconnected and re-connected during the troubleshooting process, NCVs will appear back online after repairing the system, but DTC errors will still exist until the system power is cycled off then back on. Cycle power to RCM-S ECU by going to <i>Diagnostics</i> -> <i>Tests</i> -> <i>Reboot Product Controller</i>. Replace NCV and Recalibrate NCV's by going to <i>Diagnostics</i> -> <i>Tests</i> -> <i>Calibrate NCVs</i>
523077	.31	NCV offline - multiple	
523078	.2	NCV invalid index single	
	.31	NCV not indexed single	
523079	.2	NCV invalid index multiple	
	.31	NCV not indexed multiple	
523082	.2	NCV CAN error limit - single	
523083	.2	NCV CAN error limit multiple	
523084	.31	NCV unexpected reset - single	
523085	.31	NCV unexpected reset - multiple	
523138	.31	NCV bus shutdown - single	
523139	.31	NCV bus shutdown - multiple	

Code ID		Description	Recommended Actions
523140	.13	NCV poppet health limit - single	<ul style="list-style-type: none"> • Check NCV for debris, damaged or worn poppet or spring, corrosion, and any sort of contamination. Clean or rebuild NCV as necessary.
	.31	Stuck poppet - single	
523141	.13	NCV poppet health limit - multiple	<ul style="list-style-type: none"> • Check system strainer size. Ensure a 80 mesh or finer is being used. • Check plumbing system and strainers for debris, particle deposits, metal filings or any material that may cause plugging. Clean out system plumbing or strainer. • Check that correct tip size is selected and installed. Consider increasing tip size. • Check for error to extinguish at different NCV duty cycles or product flow rates
	.31	Stuck poppet - multiple	
523142	.31	Unexpected system flow decrease	<ul style="list-style-type: none"> • Check sprayer plumbing for any major blockage in system or a major leak ahead of flowmeter. • Check that any sump, master valves, electric boom valves, hand valves, throttling valves, check valves, and drain valves are open, not obstructed, or in correct positions. • Check for pinched hoses. • Check strainers for obstructions. Clean if necessary. • Check that correct tip size is selected and installed. • Check for empty product tank. • Check for correct flowmeter calibration value. • Check system pump for proper operation.
523143	.31	Unexpected system flow increase	<ul style="list-style-type: none"> • Check sprayer plumbing for a major leak downstream of flowmeter. • Check that correct tip size is selected and installed on all tips and fence row nozzles. • Check that electric or manual valves are in correct positions. • Check for correct flowmeter calibration value.
523192	.13	Spurge pressure sensor not calibrated	<ul style="list-style-type: none"> • Select correct spurge pressure sensor calibration value.
	.4	Spurge pressure sensor not detected	<ul style="list-style-type: none"> • Check the spurge transducer connection and cabling for damage. If necessary, replace the cable or pressure sensor.

Code ID		Description	Recommended Actions
523193	.16	High NCV efficiency	<ul style="list-style-type: none"> Means that NCV duty cycle is LOWER [$<90\%$] than expected for entered tip size, current flow, and pressure. Check that correct tip size is selected and installed. Decrease tip size if needed. Check if NCVs are sticking open. Clean if open. Check flowmeter calibration. May need to increase flowmeter calibration number. Check if fencerows, boom sections, flush or drain valves are open by mistake. Go to <i>Diagnostics -> System Information -> Delivery System</i> and check actual amount sprayed against amount reported by flowmeter or tank level. Go to <i>Tools -> Applicator Setup -> Section Setup Summary</i> and verify that section and tip spacing calibration values are correct. Adjust if necessary by editing the machine profile. Check sprayer plumbing for major leak downstream of flowmeter. Check NCV efficiency alarm limit. Check if boom transducer is functioning correctly in pressure sensor readings.
	.18	Low NCV efficiency	<ul style="list-style-type: none"> Means that NCV duty cycle is HIGHER [$>105\%$] than expected for entered tip size, current flow, and pressure. Check that correct tip size is selected and installed. May need to increase tip size. Check if spray tips or NCVs are partially blocked. Clean if blocked. Check flowmeter calibration or possible blockage. May need to decrease flowmeter calibration number. Go to <i>Diagnostics -> System Information -> Delivery System</i> and check actual amount sprayed against amount reported by flowmeter or tank level. Go to <i>Tools -> Applicator Setup -> Section Setup Summary</i> and verify that section and tip spacing calibration values are correct. Adjust if necessary by editing the machine profile. Check sprayer plumbing for major leak between pump and flowmeter or a blockage past flowmeter. Check strainers for blockage. Clean if needed. Check NCV efficiency alarm limit. Check if boom transducer is functioning correctly in pressure sensor readings. Check system pump for proper operation.

Code ID		Description	Recommended Actions
523232	.18	Minimum pressure	<ul style="list-style-type: none"> • Check if tank is empty. • Check if strainer is blocked. Clean if necessary. • Check for system leak. Repair as needed. • Check target pressure and rate. Increase if necessary. • Increase travel speed. • Check if tank sump is closed. Open if not. • Check if master valve is closed. Open if not. • Check Minimum Pressure setting. Decrease if necessary. Value should be >6psi. • Check if boom transducer is functioning correctly in pressure sensor readings. • Check the boom pressure transducer connection and cabling. If necessary, replace cable or pressure sensor. • Check wiring to pump pwm valve. Make sure connections are secure. • Go to manual mode and increase DC to see if pump is working and pressure builds with increasing control effort. • Check PWM MAX value is >30. • Check PWM control range using PWM Health Test. Overall range should be >20%.

Code ID		Description	Recommended Actions
523232	.16	Maximum pressure	<ul style="list-style-type: none"> • Check entered and installed spray tip size and target rate, pressure, and desired speed. Adjust any parameters as necessary. Consult tip manufacturer for sizing proper spray tip. • Check recommended PWM control range using PWM Health Test. • Check that PWM MAX \leq 82%, Tank Fill and Standby PWM \leq 75%. Decrease PWM setting or engine RPM during pump operation for spraying, filling, or standby as needed. • Check strainers for blockage. Clean if necessary. • Check for electric or manual valves between pump and spray tips are opening properly. • Check if pump transducer is functioning correctly in pressure sensor readings. • Check if boom transducer is functioning correctly in pressure sensor readings. • Check the pressure transducer connections and cabling for damage. If necessary, replace the cable or replace pressure sensor. • Check Maximum Pressure setting against desired operating or target pressure. Increase if necessary. Maximum recommended operating pressure is 120 psi. System will shut down if pressure exceeds 150 psi. • Check standby pressure setting. Decrease if necessary.
	.4	Boom pressure sensor not detected	<ul style="list-style-type: none"> • Check the boom pressure transducer connection and cabling for damage. If necessary, replace the cable or replace pressure sensor.
523252	.13	New injection pump detected	<ul style="list-style-type: none"> • Edit existing or create a new profile and calibrate injection pump. • Cycle system power.
	.31	Injection pump lost communication	<ul style="list-style-type: none"> • Cycle system power. • Check fuses and cabling and power, ground and CAN to injection pumps. Repair or replace as necessary. • Replace injection pump ECU.

Code ID		Description	Recommended Actions
523234	.13	Pump pressure sensor not calibrated	<ul style="list-style-type: none"> • Select correct pump pressure sensor calibration value. • Check the pump pressure transducer connection and cabling for damage. If necessary, repair or replace cable or replace pressure transducer.
	.16	Pump/boom pressure differential	<ul style="list-style-type: none"> • Check strainers between pump and boom pressure sensor for blockage. Clean if necessary. • Check for electric or manual valves between pump and boom pressure sensors opening properly. • Check if pump transducer is functioning correctly in pressure sensor readings. • Check if boom transducer is functioning correctly in pressure sensor readings. • Check the pressure transducer connections and cabling for damage. If necessary, replace the cable or replace pressure sensor.
	.4	Pump pressure sensor not detected	<ul style="list-style-type: none"> • Check the pump pressure transducer connection and cabling for damage. If necessary, replace the cable or replace pressure sensor.
524082	.31	UT display is offline	<ul style="list-style-type: none"> • Cycle system power. • Check cabling and power, ground, and CAN connections to UT. Repair or replace if necessary.
524083	.31	AUX-N Input Offline	<ul style="list-style-type: none"> • Cycle system power. • Check cabling and power, ground, and CAN connections to AUX-N device. Repair or replace if necessary.

NOTE: If any DTC or of the following Notifications appear and are not expected during normal operation, follow the listed Recommended Actions.

Type	Description	Recommended Actions
Notification	Activation required	<ul style="list-style-type: none"> • Cycle power to system and check unlocked features. • Consult dealer for desired unlock. • Replace ECU.
	Boom purge in progress	<ul style="list-style-type: none"> • Check boom purge status. • Cycle system power.
	Boom rinse in progress	<ul style="list-style-type: none"> • Check boom rinse status. • Cycle system power.
	Diagnostic application control	<ul style="list-style-type: none"> • Go to <i>Tools -> System Settings -> User Settings -> Wireless Control Mode</i> and set to "Off." • Turn off wireless remote by pressing and holding Red 0 button for 3 seconds on handheld remote. • Cycle power to RCM-S ECU by going to <i>Diagnostics -> Tests -> Reboot Product Controller</i>.
	Fill in progress	<ul style="list-style-type: none"> • Check fill switch position.
	Hardware init error - multiple	<ul style="list-style-type: none"> • Cycle power to system.
	Hardware init error - single	<ul style="list-style-type: none"> • Replace affected NCVs.
	Low recirculation flow	<ul style="list-style-type: none"> • Check for pinched boom supply or recirculation hoses. • Check that any sump, master valves, electric boom valves, hand valves, throttling valves, check valves, and drain valves are open, not obstructed, or in correct positions. • Check strainers for obstructions. Clean if necessary. • Check that recirculation valve is opening. • Check for empty product tank. • Check that pump is on and standby PWM is >30. • Check that low flow limit is <10 gpm. • Check for obstructions in strainers, flowmeter, and check valves. • Check for correct flowmeter calibration value.

Type	Description	Recommended Actions
Notification	Low pressure shutdown	<ul style="list-style-type: none"> • Check if tank sump is closed. Open if closed. • Check if tank is empty. • Check if master valve by flowmeter is opening. Open if closed. • Check if pump transducer is functioning correctly in pressure sensor readings. • Check if boom transducer is functioning correctly in pressure sensor readings. • Check wiring to pump pwm valve. Make sure connections are secure. • Check to see if pump is turning on when product turns on. (Go to manual mode and ramp up DC to see if pump is working and pressure builds with increasing control effort.) • Check PWM MAX value is >30. • Check PWM control range using PWM Health Test. Overall range should be >20%.
	Low tank	<ul style="list-style-type: none"> • Check actual vs displayed Current Tank Level. Adjust if necessary. • Check Low Tank Level limit and alarm value. Adjust if necessary. • Check Flow Meter operation, Calibration value, and Meter Pulse/Units. Repair or recalibrate if necessary. • Check Fill Flow Meter or Fill Level Sensor operation, Calibration value, and Units if installed. Repair or recalibrate if necessary.
	NCV high flow limit - multiple	<ul style="list-style-type: none"> • Decrease operation or turning speed. • Check for correct target rate and pressure. • Check for low NCV efficiency number. - Should normally be between 90 and 105. • Check for correct tip size for desired rate, speed, and pressure. • Check flowmeter calibration value, as it may be too low. • Check poppets for obstructions. • Ensure all boom valves or electronic valves are opening correctly. • Check strainer for plugging. • Check for leaks. • Check for pinched hoses.
	NCV high flow limit - single	<ul style="list-style-type: none"> • Decrease operation or turning speed. • Check for correct target rate.

Type	Description	Recommended Actions
Notification	NCV low flow limit - multiple	<ul style="list-style-type: none"> • Increase operation speed or turning rate. • Check for correct target rate and pressure. • Check for high NCV efficiency number. Should normally be between 90 and 105. • Check for correct tip size for desired rate, speed, and pressure. • Check flowmeter calibration value, as it may be too high. • Check poppets for excessive wear.
	NCV low flow limit - single	<ul style="list-style-type: none"> • Increase operation speed or turning rate. • Check for correct target rate.
	NCV retransmission - multiple	<ul style="list-style-type: none"> • Go to <i>Diagnostics</i> -> <i>Diagnostic Trouble Codes</i> -> <i>NCV Errors</i> -> <i>NCV Heat Map</i> and locate the NCV(s) that are not green. Their numerical locations are labeled referencing the forward travel direction, from leftmost to rightmost NCV along the boom. Note their location for future reference and troubleshooting as necessary. • Cycle power to RCM-S ECU by going to <i>Diagnostics</i> -> <i>Tests</i> -> <i>Reboot Product Controller</i>. • Replace affected NCVs. Then recalibrate NCVs by going to <i>Diagnostics</i> -> <i>Tests</i> -> <i>Calibrate NCVs</i>. If necessary, check NCV software by going to <i>Diagnostics</i> -> <i>Tests</i> -> <i>NCV Updates</i> to scan and update software on affected NCVs.
	NCV retransmission - single	
	NCV zero flow target - multiple	<ul style="list-style-type: none"> • Check for correct target rate.
	NCV zero flow target - single	
	Off pressure high	<ul style="list-style-type: none"> • Check for correct target pressure. • Check for electric or manual valves are opening correctly. • Check strainers and check valves for obstructions. • Check for damaged pressure sensor or cabling. • Check for correct tip size. • Check pump for proper operation. • Check Off Pressure Alarm % value.

Type	Description	Recommended Actions
Notification	Off pressure low	<ul style="list-style-type: none"> • Check for low tank level. • Check for correct target pressure. • Check for electric or manual valves and sump are opening correctly. • Check strainers and check valves for obstructions. • Check for damaged pressure sensor or cabling. • Check for correct tip size. • Check for system leak. • Check pump for proper operation. • Check Off Pressure Alarm % value.
	Off rate high	<ul style="list-style-type: none"> • Increase operation speed. • Check for correct target rate. • Check NCV efficiency number. - Should be between 90 and 105. • Check for correct tip size for desired rate, speed, and pressure. • Check flowmeter calibration value. - May be too low. • Check poppets for excessive wear. • Check for leaks. • Turn on more sections. • Check Off Rate Alarm % value.
	Off rate low	<ul style="list-style-type: none"> • Decrease operation speed. • Check for correct target rate. • Check NCV efficiency number. - Should be between 90 and 105. • Check for correct tip size for desired rate, speed, and pressure. • Check flowmeter calibration value. - May be too high. • Check poppets for obstructions. • Ensure all boom valves or electronic valves and sump are opening correctly. • Check strainer for plugging. • Check for pinched hoses. • Turn off more sections. • Check Off Rate Alarm % value.

Type	Description	Recommended Actions
Notification	Product 1: valve PWM max	<ul style="list-style-type: none"> • Check for electric or manual valves and sump opening properly. • Check tip sizes and target rates and pressures. • Increase engine RPM. • Decrease operation speed. • Check pressure and flow sensor operation. • Check sparge or recirculation system valve positions. • Check PWM MAX value. • Check PWM control range using PWM Health Test. Overall range should be >20%. • Check target flow or pressure against machine pump and delivery system specifications.
	Product 1: valve PWM min	<ul style="list-style-type: none"> • Check for electric or manual valves opening properly. • Check tip sizes and target rates and pressures. • Decrease engine RPM. • Increase operation speed. • Check pressure and flow sensor operation. • Check sparge or recirculation system valve positions. • Check PWM MIN value. • Check PWM control range using PWM Health Test. Overall range should be >20%. • Check target flow or pressure against machine pump and delivery system specifications.
	Road mode active	<ul style="list-style-type: none"> • Check road position switch for "On" condition.
	Tank rinse in progress	<ul style="list-style-type: none"> • Check tank rinse status. • Cycle system power.
	Zero speed shutoff	<ul style="list-style-type: none"> • Increase vehicle speed and cycle master switch.
	Tank level sensor not calibrated	<ul style="list-style-type: none"> • Calibrate tank level sensor. • Cycle system power.
	Tier overlap error	<ul style="list-style-type: none"> • Check target rates and pressure. Adjust if necessary. • Check installed and recommended tip sizes. Adjust if necessary.

Type	Description	Recommended Actions
Notification	Pump RPM above maximum	<ul style="list-style-type: none"> • Check Engine RPM. Increase if necessary. • Check Max Pump RPM value. Increase if necessary. • Check Target Rate and Pressure. Decrease if necessary. • Check Max Pump PWM value. Decrease if necessary. • Check if tank is empty. • Check if pump is primed with product. • Check if tank sump is closed. Open if closed. • Check Pump Health and operation using PWM Health Test. Additionally troubleshoot pump or PWM valve if necessary.
	Pump RPM below minimum	<ul style="list-style-type: none"> • Check Pump RPM sensor and cabling. Repair or replace if necessary. • Check Engine RPM. Increase if necessary. • Check Target Rate and Pressure. Increase if necessary. • Check Min Pump PWM value. Increase if necessary. • Check Pump Health and operation using PWM Health Test. Additionally troubleshoot pump or PWM valve if necessary.

SYSTEM SUMMARY

Displays information configured during the setup process but does not provide the option to modify the configuration:

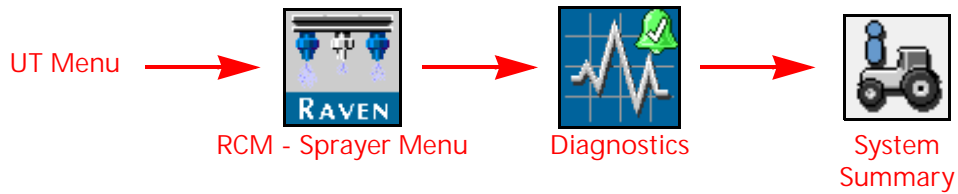

1. Open the UT Menu and select the RCM - Sprayer Menu button.
2. Select the Diagnostics softkey along the right side of the page.
3. Select the System Summary tab.

NCV DIAGNOSTICS

NOTE: NCV Diagnostics are not available in Bypass NCV operation mode.

To access Hawkeye® 2 nozzle control valve diagnostics information by configured section:

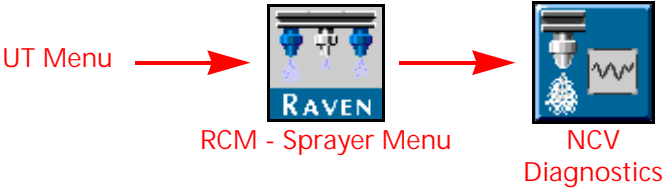

- 1. Open the UT Menu and select the RCM - Sprayer Menu button.
- 2. From the home screen, select the NCV Diagnostics button in the lower portion of the screen. The following settings and information may be displayed for each configured section:

NOTE: The NCV Diagnostics button is displayed on the Home page in the lower portion of the page. It may be necessary to toggle the lower display to either the tank level or analog gauge view.

FIGURE 1. NCV Diagnostics Display

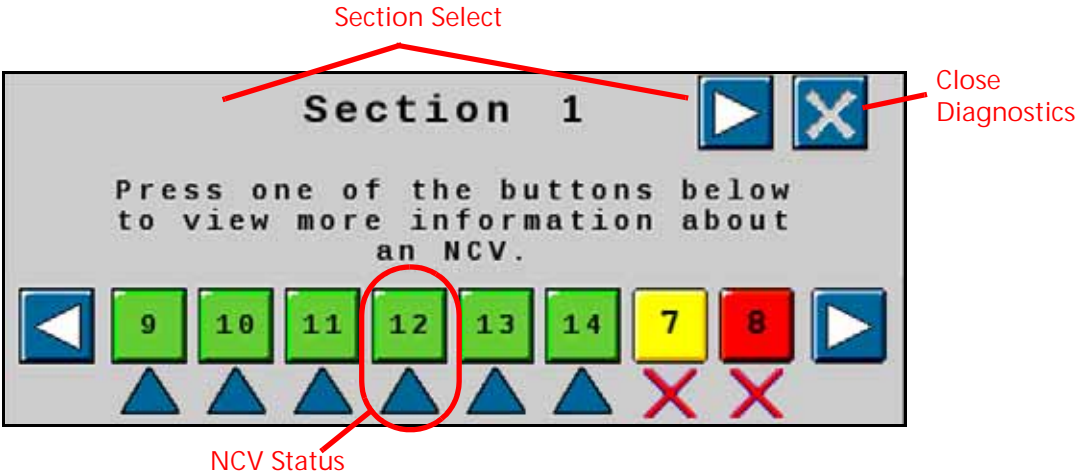

NOTE: Selecting an NCV with a green or yellow status will display the NCV Readings page while selecting an NCV with a red status will display the NCV Errors page.

NCV SELECT





Press the NCV select arrow to cycle through each individual NCV status.

CURRENT SECTION DISPLAY

The current section for which diagnostic information is being displayed is shown at the top of the NCV diagnostics prompt. Select the left or right section select arrow buttons to cycle through sections configured for use with the Hawkeye® 2 nozzle control system.

SECTION NCV STATUS

The status of each NCV configured for control on the section is displayed at the bottom of the section diagnostics prompt. The following NCV statuses may be displayed while viewing the section diagnostics prompt:

-  Normal. The NCV is functioning normally and no alarm conditions are currently present.
 -  Caution. A minor NCV alert condition has been detected. The control system and NCV PWM is operating normally, however, the system has detected that a condition exists which could impact the current application.
 -  Critical. A critical NCV condition has caused the NCV to shut down. The NCV is not responding as expected and the operator should cease application and troubleshoot the issue before resuming operations.
 -  Not Calibrated. The NCV section is not calibrated.
- NOTE: Refer to Chapter 9, *Troubleshooting*, for additional assistance with diagnostic trouble codes and using the DTC list.

INDIVIDUAL NCV DIAGNOSTICS

To access individual Hawkeye® 2 NCV diagnostic information:

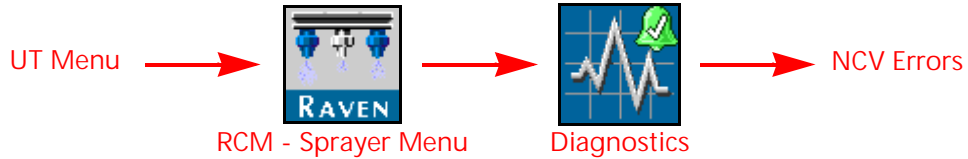

1. Open the UT Menu and select the RCM - Sprayer Menu button.
2. Select the Diagnostics softkey.
3. Select the NCV Errors button in the lower, right corner of the page to access the following diagnostic information for each NCV:

FIGURE 2. NCV Information

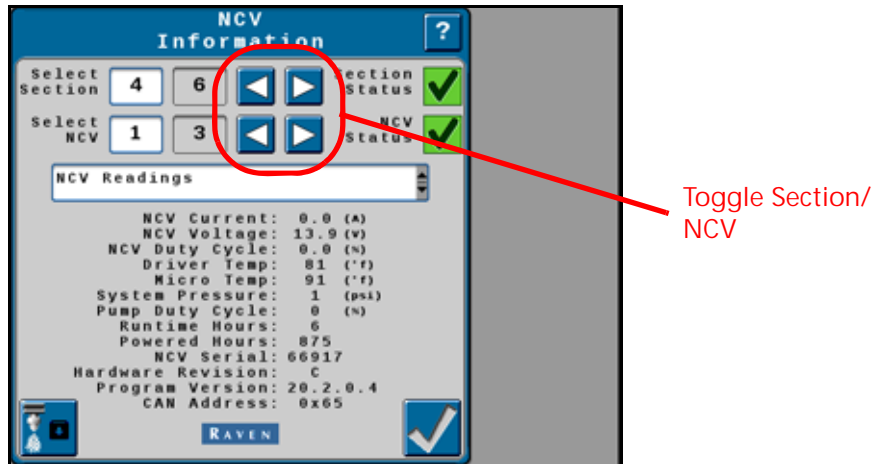

NOTE: Use the section and NCV left and right arrow buttons at the top of the NCV Diagnostics page to view different NCVs.

NCV READINGS

Current and Voltage. Each nozzle control valve provides the measured current, in amperes, and voltage at the NCV to the RCM - Sprayer ECU for display. The NCV Current should display as 0.0 Amps when the selected NCV is not operating and should be 0.3 - 0.7 Amps during normal operation. Voltage should be 10.5 - 16.0 V during normal operation.

NCV Duty Cycle. Each NCV reports the current NCV duty cycle over the communication network. Values should increase or decrease as expected for changes in speed, target rate, in a turn, and when a flow offset is enabled. Values go to zero when master switch or all boom switches are off.

Driver Temp and Micro Temp. Component temperatures on the Hawkeye® 2 nozzle control valve circuit board.

System Pressure. The monitored system pressure reported by the Hawkeye® 2 spray boom pressure transducer.

Pump Duty Cycle. The current pump effort.

Runtime Hours. The total time which the NCV has been active.

Powered Hours. Total time the NCV has been powered on.

NCV Serial. Serial number of the NCV for which the information is being displayed.

Hardware Rev. This is the PCB hardware revision level of the NCV. This is not the same as the assembly revision level which is shown on the NCV label.

NOTE: The PCB hardware revision may differ from the revision displayed on the NCV assembly. The NCV assembly revision shown on the NCV label will be most helpful when seeking technical support.

Program Version. The version of software loaded on each NCV. This information may be helpful to troubleshoot individual NCVs or to ensure proper operation of the nozzle control system.

CAN Address. The unique location of the NCV on the nozzle bus.

NCV UPDATES

To update Hawkeye® 2 NCVs on the nozzle bus:

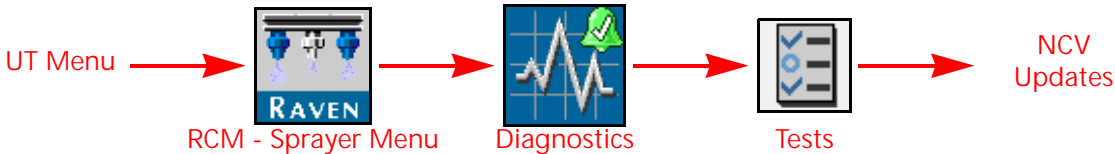

1. Open the UT Menu and select the RCM - Sprayer Menu button.
2. Select the Diagnostics softkey.
3. Select the Tests tab along the top of the page.
4. Select the NCV Updates in the dropdown list and follow the on-screen instructions to update NCVs on the nozzle bus.

RCM - SPRAYER STATUS LED

There are four LEDs on the front of the ECU. Each LED color and flash rate indicates different information as detailed in the table below. If multiple states are true for a given LED the first active state listed in the table will be the state displayed. After addressing the displayed state (if needed), the next LED state will be indicated.

FIGURE 1. RCM - Sprayer LEDs



TABLE 1. RCM - Sprayer LED Status

LED Indicator			State
LED	Color	Flash Rate	
Power	Green	Solid	ECU is powered on.
A	Off	Solid	Microprocessor is not powered.
	Any	Solid	Microprocessor has stopped functioning.
	Yellow	1	Active when the boot loader enters boot hold mode.
	Red	5	Active when the microprocessor is being programmed.
		1	Active if the ISOBUS is offline.
	White	1	Active if the UT is offline.
	Purple	1	Loop back test mode enabled.
Green	1	Active when linked with UT and system is normal.	
B	Red	Solid	PCB subsystem not running (FPGA).
		1	System has lost ECU power.
	Blue	1	Signal is present on 1 or more rate sensors.
	Yellow	1	One or more DTCs are active.
	White	1	System voltage is below 11.5 volts.
	Purple	1	System voltage is above 16 volts.
	Blue	Solid	One or more product switches have been set to On.
	Purple	Solid	Signal is present on one or more RPM sensors.
	Green	Solid	All product switches have been set to Off.
	Red	Solid	One or more loop back subtests failed in this current test sequence.
	Yellow	Solid	One or more loop back subtests failed in the previous test sequence.
Green	Solid	No loop back subtests have failed.	
C	Red	Solid	PCB subsystem not running (FPGA).
	Blue	1	Bluetooth command has been received.
	Blue	Solid	Bluetooth communication is active.
	Green	1	The Auxiliary CAN channel is active.
	Red	1	Active if the Auxiliary CAN channel was active and is now offline.
	Green	Solid	LED C is functional and there are no other LED C states to report.
	Purple	Solid	A loop back test is in progress.
	Green	Solid	A loop back test is not in progress.

NCV TECHNICAL SPECIFICATIONS

TABLE 2. Hawkeye® 2 Nozzle Control Valve Technical Specifications

		U.S.	Metric
Dimensions	Height	2.9 in.	7.32 cm
	Width	2.7 in.	6.73 cm
	Depth	1.6 in.	40 cm
	Weight	approximately 8.0 oz.	approximately 0.225 kg
Power	Operating Voltage	10.5 to 36 VDC nominal	
Input/Output	Max. Operating Pressure	120 PSI	827.4 kPa
Environmental	Operating Conditions	14° to 167° F	-10 to 75° C
	Storage Conditions	-40° to 185° F	-40° to 85° C
	Relative Humidity	10 to 95%	

HAWKEYE® 2 NOZZLE CONTROL VALVE STATUS

FIGURE 2. Nozzle Control Valve LED



TABLE 3. Hawkeye® 2 NCV LED Status

LED Indicator	Rate	Color	State	Before Calibration	After Calibration	Profile Detected, Not Calibrated	Note
Flashing	1 Hz	Green	NCV Ready to Apply		X		Normal State - Will flash when system is fully calibrated.
		Yellow	NCV Missing Calibration or Active DTC		X	X	Normal State - Will flash after NCVs have been indexed, but calibration is not complete. Error State - Active DTC for the system.
		Red	Lost communication between RCM-SECU and NCV or NCV has < 9V HC power.	X	X	X	Normal State - Will flash when NCVs are not calibrated or when editing a profile until the NCVs have been detected.
		Blue	NCV has not claimed a CAN address or no CAN communication received by NCV.	X	X	X	Normal State - Quick blue flash after calibration has been initiated, then will start flashing red. Error State - Will flash slow blue if it has lost communication with upstream NCV.
Flashing	4 Hz	Green	NCV Commanded to Apply		X		Normal State - Will flash when NCV is commanded to apply or when active width is non-zero.
		Blue	NCV CAN Channel Errors		X		Error State - Will flash fast blue if it has lost communication with downstream NCV.
	5 Hz	Red	NCV in Bootloader Mode		X		Normal State -Flashes during software update.
	-	Blue	CAN Pass-Through Disabled		X		Error State - Will be solid blue for a short time, then will begin flashing to indicate a communication error with a nearby NCV.
Solid	-	White	NCV Selected on UT info Page		X		Normal State - Solid when a specific NCV is selected on the UT screen.
	-	-	No Power		X		Normal State - Will be off when NCV is not powered or speed is greater than 2mph [3.22 km/h]

NCV OFFLINE TROUBLESHOOTING

If an NCV Offline error occurs with the system, there are several ways to diagnose where the problem may exist.

Always have the engine running when performing the NCV diagnostic tests to ensure there is sufficient electrical power available to the system. If NCVs are moved around, disconnected, or replaced, it may be necessary to cycle power to the system and recalibrate to clear any errors and properly reestablish communication.

When making wiring or connection repairs, turn off the engine and disconnect battery power to safely work on the equipment. When wiring repairs are completed, it may be necessary to cycle power or recalibrate the system to ensure communication is reestablished properly to the system.

NCV ALARMS

When an NCV Offline alarm happens, whether due to loss of power, loss of communication, or another error, an alarm will display on screen.

Select the Accept (check) button to accept the error and return to the previous screen.

FIGURE 3. Example On-Screen Alarm

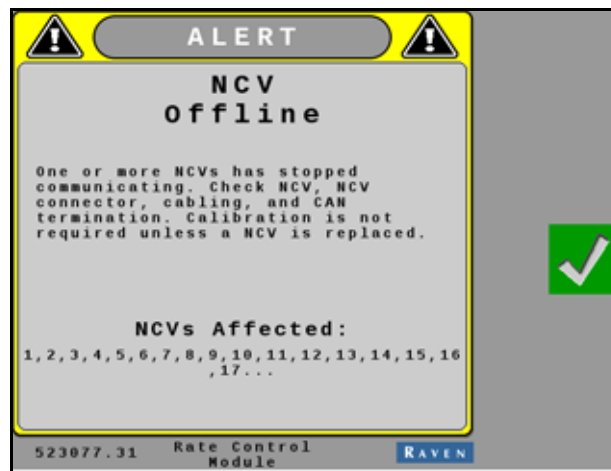

Note that the NCVs affected by the alarm are displayed on the alarm prompt. An ellipsis (...) is displayed if more NCVs are affected by the alarm condition. In this instance, just note the range of NCV IDs visible (e.g. 1-17, etc.).

NCV DIAGNOSTICS

To display active and inactive diagnostic trouble codes code information:

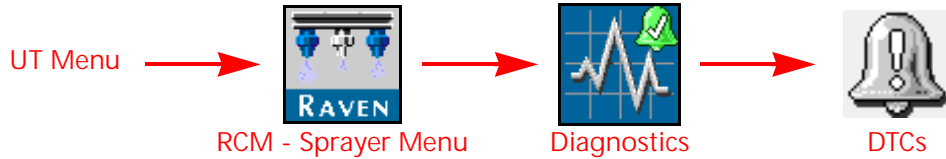

1. Open the UT Menu and select the RCM - Sprayer Menu button.
2. Select the Diagnostics softkey along the right side of the page.
3. Select the Diagnostic Trouble Codes (DTCs) tab.
 - Current trouble codes are displayed in the Active table. The DTC Identification number and occurrence count is listed.
 - Resolved trouble codes are displayed in the Inactive table. The DTC Identification number and occurrence count is listed.
4. Use the up and down arrows to scroll through the list of trouble codes. A description of the highlighted code is shown below each table.
5. If desired, press the Clear button to erase all the trouble codes listed in the Inactive table.
6. Select the Info button to review available diagnostic information for the code.

FIGURE 4. Diagnostic Information Display

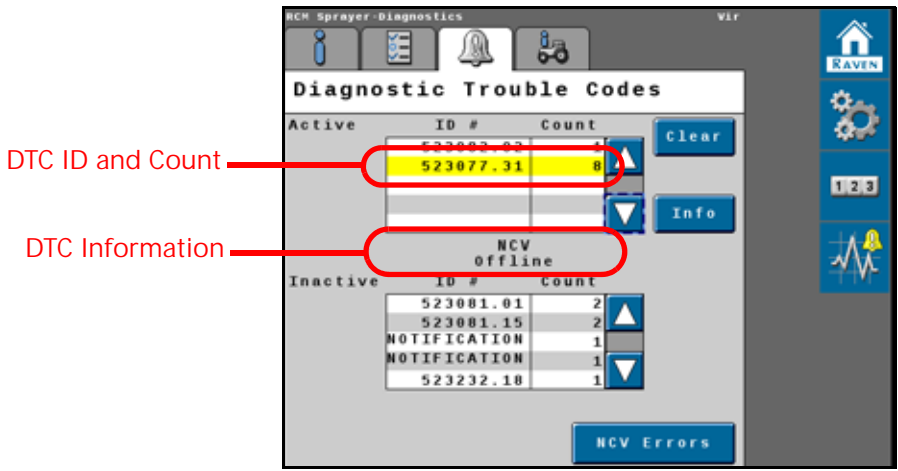

OTHER RELATED ERRORS

NCV UNEXPECTED RESET

An NCV Unexpected Reset error is encountered when an NCV was offline, then came back online.

This may be due to an intermittent power connection to NCV(s) from intermittent power or fuse connection, intermittent 19-pin connection, loose NCV connection or an NCV that is failing.

NOTE: Once the issue is resolved, the system may require a power cycle to clear this error.

NCV CAN ERROR LIMIT

This error is encountered when CAN communication is poor.

If many NCVs are affected, the problem may be with intermittent connections at 19-pin connectors, corrosion, or damage to splices or wiring harnesses where several circuits come together which would affect more than one NCV.

If only a few NCVs are affected, the issue is likely with a single NCV, NCV connection, or section of wiring in between NCVs.

NCV ERRORS AND NCV INFORMATION MENU

Select the NCV Errors button to view the NCV Information menu where other active errors for selected NCVs may be viewed.

FIGURE 5. NCV Information Heat Map

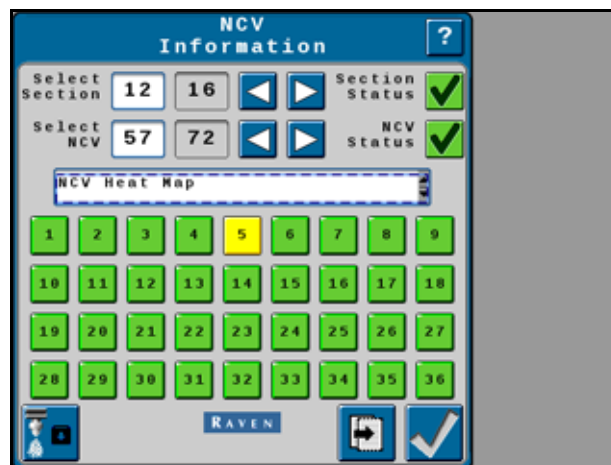

In the NCV Errors menu, select any section or specific NCVs to inspect. The drop down menu allows the operator to select the following information displays:

- NCV Readings
- NCV Settings

NOTE: NCV Settings is only available if HD Individual Nozzle Control is unlocked.

- NCV Errors
- NCV Heat Map
- Section Heat Map

Heat Map. The Heat Map selections will show you if there are any active errors for specific NCVs or sections.

Green NCV buttons represent no error for that NCV.

Yellow or Red NCV buttons represent an error.

Touch on the NCV button of interest to see NCV readings for that specific NCV. In some cases, several red buttons may precede a yellow NCV. In that case, the red NCVs are likely not communicating with the system, and the first yellow NCV is the first NCV recognized by the system. This condition may be due to an issue between the last red and first yellow NCV, such as an NCV failure, wiring issue, or fuse issue affecting the red section of NCVs.

NCV COMMUNICATION DIAGNOSTIC TEST

The NCV Communication Test can be used to locate the area of the system to inspect. To run the communication test:



1. Open the UT Menu and select the RCM - Sprayer Menu button.
2. Select the Diagnostics softkey.
3. Select the Tests tab along the top of the page.
4. Select the NCV Communication Test test in the dropdown list.
5. Select the Begin button to start the test. The system will attempt to find CAN Communication Errors on the NCV CAN bus.

Displayed NCVs are numbered on screen from left to right. These are referenced from the left side of the machine, facing the normal forward direction of travel.

If No CAN Error Detected is displayed, that means that the test has found no detectable communication errors. Left, right, and tip-to-tip latency times will be displayed

FIGURE 6. NCV Communication Test No CAN Error Detected

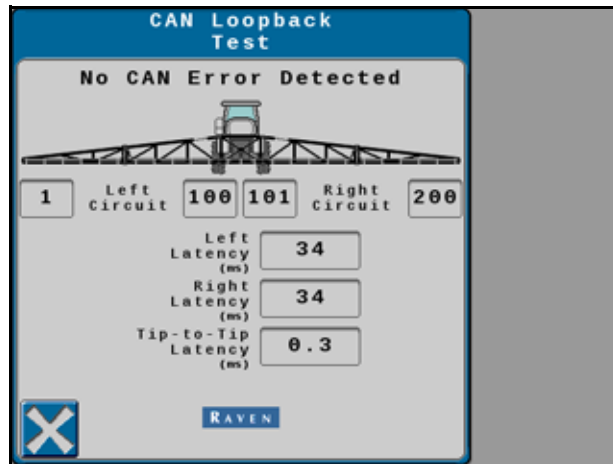

If an error occurs, note the “No Communication After NCV” number, and the “Communication Resumes At NCV” number. The issue is likely between, and possibly includes, these NCVs. Inspect NCVs on the boom, wiring, connections, or fuses related to the circuit between and including these NCVs.

If there is no communication after the #1 NCV, there may be a power loss between the battery connection and the NCV cable connections, or a CAN communication problem between the RCM - Sprayer ECU and the NCV cable connections. Inspect wiring, fuses, and connections before the left and right cable circuit branches.

GENERAL TROUBLESHOOTING

When only a few NCVs are noted, inspect nearby NCVs, connections, pins, and cabling for corrosion, visible damage, or pinching between those NCVs. In some instances, splices or wiring may be damaged underneath cable coverings.

When large sections of NCVs are not communicating, inspect those items along with fuses and large electrical connections.

If intermittent power to the NCVs is the cause of the issue, or if NCVs are disconnected and re-connected during the troubleshooting process, NCVs will appear back online after repairing the system, but DTC errors will still exist until the system power is cycled off then back on.

OTHER USEFUL TESTS

Calibrate NCVs should be used after swapping NCVs around to locate problems, or after replacing NCVs. This will ensure the NCVs are properly numbered in the system for turn compensation, section shutoff, and error detection.

Reboot Product Controller can be used instead of cycling key power to reboot and reinitialize communication to the RCM - Sprayer ECU and NCV bus.

CABLE TROUBLESHOOTING

TROUBLESHOOTING NCV CABLE CONNECTIONS

Nozzle control valve cable troubleshooting may require the system to be powered on and the NCVs disconnected.

Disconnect the boom cable from the NCV. Hold the connector so that the retention clip is facing toward the 12 o'clock position.

FIGURE 7. NCV Cable Connector

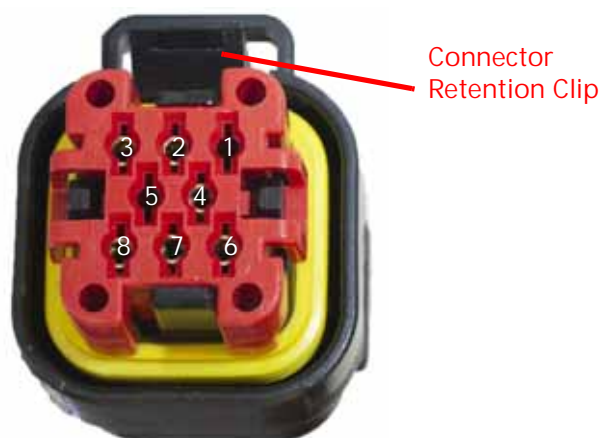

TABLE 4. NCV Cable Connector Pins

Pin	Description	Pin	Description
1	Aux Device Output (High Flow Cables Only)	5	Aux Device Input (High Flow Cables Only)
2	CAN Lo Out	6	Chassis Power (12 VDC Nominal)
3	CAN Hi Out	7	CAN Hi In
4	Chassis Ground (0 VDC)	8	CAN Lo In

TROUBLESHOOTING 19-PIN BOOM CABLE CONNECTIONS

Boom connection cables alternate NCV power and ground circuits within the cable for banks of NCVs. Adjacent NCVs may not necessarily not be on the same HC power and ground circuit. Look at the end of the plug to locate the pin numbers.

TABLE 5. Boom Cable Connection Pins

Pin	Description	Pin	Description
1	-	11	-
2	-	12	HC Circuit 2 Power
3	CAN Hi Return	13	-
4	CAN Lo	14	HC Circuit 2 Ground
5	-	15	-
6	CAN Hi	16	HC Circuit 3 Power
7	CAN Lo Return	17	Fence Row
8	HC Circuit 1 Power	18	HC Circuit 3 Ground
9	-	19	-
10	HC Circuit 1 Ground		

TROUBLESHOOTING TERMINATOR CONNECTIONS NEAR THE RCM

Terminator connection referenced from cable side.

TABLE 6. Terminator Connection Pins

Pin	Description
A	CAN Hi
B	CAN Lo
C	-

TROUBLESHOOTING FLOW METER CABLES

Disconnect the extension cable from the flow meter. Hold the extension cable so that the keyway is facing toward the 12 o'clock position.

FIGURE 8. Flow Meter Extension Cable Pin Diagram (Con-X-All)

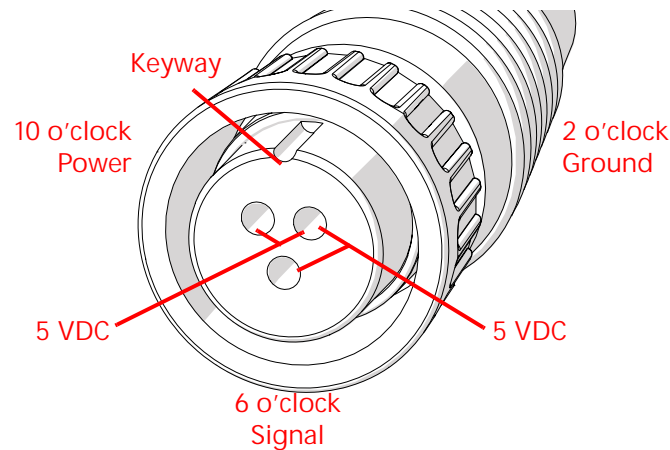

TABLE 7. Flow Meter with Deutsch DT Connector

Pin	Function
A	Power
B	Ground
C	Signal

TABLE 8. Flow Meter with Deutsch DTM Connector

Pin	Function
1	Signal
2	Ground
3	Power

TEST THE FLOW METER CABLE

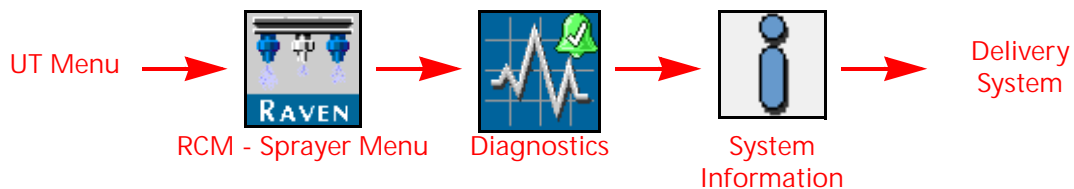

To test the flow meter cable:

1. Open the UT Menu and select the RCM - Sprayer Menu button.
2. From the home screen, change the product Rate Control Mode to Manual.

NOTE: Ensure the control valve output is zero.

3. Access the Tools Menu and select the Rate Setup and set the Flow Meter Calibration value to 1.
4. Change the Flow Meter Pulse/Units to 1 (not 10 pulses per unit).

5. Return to the Home page and note the existing volume in the tank.
6. Toggle at least one section switch and the master switch to the on position.
7. Use a small jumper wire (e.g. paper clip) to short the ground and signal sockets with a “short-no short” motion. Each time the short is made, the total tank volume value should change by increments of one or more.
8. If the tank level does not decrease, disconnect the flow meter extension cable if installed and repeat this test at the next connector closest to RCM - Sprayer ECU. Replace defective cable as required.
9. If all cables test good, replace the flow meter.
10. After testing is complete, re-enter correct meter cal value, units, and tank level.

GENERAL TROUBLESHOOTING

Problem	Action
Adjacent nozzle control valves pulsing at same time.	<ul style="list-style-type: none"> • Check cabling connections. • Check NCV diagnostics and DTC list for nozzle control valve errors. • Perform the Calibrate NCVs test or Edit Profile to reindex the nozzle control valves across the implement width. • Contact a local Raven dealer for additional assistance.
Rate reads “0.”	<ul style="list-style-type: none"> • Verify SPEED is registering accurately. If SPEED is zero, refer to the UT display troubleshooting procedure. • Verify TOTAL VOLUME is registering flow. • Confirm the boom section status shows on the display changes when section switches are activated in manual operation.
Cannot connect to wireless remote for diagnostics	<ul style="list-style-type: none"> • Verify desired Wireless Control Mode is selected. • Verify wireless remote is within line of sight to the RCM - Sprayer ECU. • Verify wireless remote is turning on and batteries are charged. • Verify a Device Passcode entered into wireless remote matches passcode shown on System Alert.
Intermittent connection to BLE wireless remote	<ul style="list-style-type: none"> • Verify wireless remote is within line of sight to RCM - Sprayer ECU. • Verify the batteries in the wireless remote are charged.
Cannot control with the wireless remote	<ul style="list-style-type: none"> • Verify the wireless remote is connected to RCM - Sprayer ECU. • Verify the desired wireless control mode is selected in User Settings screen on RCM - Sprayer ECU. • Verify all boom section switches and master switch are toggled “ON” on the machine control panel or joystick.

Problem	Action
Pressure or rate inaccurate or unstable.	<ul style="list-style-type: none"> • Verify that all calibration numbers and settings are correct. Verify SPEED is registering accurately. If SPEED is inaccurate, refer to the UT display troubleshooting procedure. • Verify that all air has been removed from the boom by priming the boom or recirculating. See “Automated Boom Prime” on page 57 or “Boom Recirculation” on page 40 for more information. • Verify the pressure transducer is selected correctly. • Verify Flow Meter calibration value and target rate is within overall flow range. • Verify control valve is operating correctly. Perform the PWM health test described in “Perform the PWM Health Test” on page 64 to inspect control range. • In MAN (manual) operation, verify that Pressure and Rate display holds constant. • Confirm that boom section status shown on the display is not changing. • Verify ECU Inertial sensors are calibrated and performing correctly. Refer to “Enable Turn Compensation” on page 38 or “Turn Compensation Feature Inspection” on page 133 for more information. Disable Turn Compensation if necessary to see if pressure or rate stabilizes. • Perform a self-test with boom master switches on to verify the rate, pressure, and area/hour are steady while sitting still. • In MAN (manual) operation, check low end and high end pressure and flow range. • In the Control Valve menu, decrease the Valve Response Rate if pressure and rate oscillate greatly in AUTO mode. Increase the valve response rate if control is unresponsive. • In the Control Valve Settings menu, decrease the NCV response sensitivity if system pressure and rate oscillate slightly in AUTO mode. Increase if the system is unresponsive. Avoid setting both the Valve Response Rate and NCV Response Sensitivity above 70.
Cannot adjust rate or pressure in automatic or manual operation.	<ul style="list-style-type: none"> • Verify the pump switch is turned on in the UT or machine console. • Verify the pump and NCV PWM values are increasing or decreasing in the diagnostic screen. • Check cabling to control valve for breaks. • Check connections in cabling for cleanliness. • Verify that there is voltage at the valve connector by toggling master switch on and setting the system to Manual. Manually change pump PWM and verify voltage changes at the valve. • If voltage to the valve is changing smoothly when actuating in Manual mode, but the control valve or pump are not adjusting pressure, inspect or replace the control valve or pump.

Problem	Action
Sprayer pressure is correct but RATE is low.	<ul style="list-style-type: none"> • Verify that strainer screens or check valves are not plugged. • Verify that pressure at each boom is the same. • Verify all spray tips are correctly sized on the sprayer and entered correctly in the Select Tip menu. • Verify correct flow meter and pressure transducer calibration values.
Total volume does not register or registers flow inaccurately.	<ul style="list-style-type: none"> • Check flow meter cable for damaged wires or corroded connections. See the <i>Cable Troubleshooting</i> section on page 95. • Check the internal components of the flow meter; clean and adjust. <i>Flow Meter Maintenance</i> section on page 125 for flow meter cleaning and adjustments. • Replace flow meter. • Verify that arrow on flow meter is pointing in direction of flow. • Verify the flow meter calibration value and units and adjust as necessary. Refer to the <i>Flow Meter Maintenance</i> section on page 125 for additional flow meter calibration information.
Boom valve(s) will not operate.	<ul style="list-style-type: none"> • Check boom valve cables and connections for damaged wires or corroded connections. • Check boom valve fuses. • Verify the switches and boom valves are mapped correctly. • Check connectors near the center rack and at the RCM - Sprayer ECU for cleanliness or corrosion. • Check BOOM switch and MASTER switch for operation. • Replace boom valve(s).
Pressure inaccurate or unstable.	<ul style="list-style-type: none"> • Verify the correct pressure for the transducer is selected. • In the Control Valve Settings, lower the Valve Response Rate to stabilize the system. • Verify the pressure on UT matches separate external mechanical gauge.
Individual NCV will not communicate with Raven Service Tool Action	<ul style="list-style-type: none"> • Verify power to the NCV. • Verify the NCV cable connection voltages fall within the desired range. • Cycle power to the system. • Recalibrate the system. • Replace the NCV.
Cannot detect BLE (Blue-tooth low energy) device for diagnostics	<ul style="list-style-type: none"> • Verify Bluetooth functionality is turned on for mobile device. • Verify another mobile device isn't already connected to the RCM - Sprayer ECU. • Verify that the mobile device is BLUETOOTH® Low Energy compatible running ISO version 8.1 or newer or Android Version 5 or newer. • Verify the mobile device is within line of sight to the RCM - Sprayer ECU.

APPENDIX

A

AVOIDING SKIPS WITH HAWKEYE® 2 NOZZLE CONTROL SYSTEM

OVERVIEW

When added to the RCM - Sprayer control system, the Hawkeye® 2 nozzle control system is designed to pulse each spray tip using an alternating pattern across the implement width. This alternating nozzle spray pattern relies upon an overlapping spray tip pattern and droplet dispersion to achieve complete and even coverage during field applications.

RECOMMENDATIONS FOR HAWKEYE® 2 NOZZLE CONTROL OPERATION

Maintain the following application system conditions will help to ensure consistent, even coverage during field applications using the Hawkeye® 2 nozzle control system:

1. Use the appropriate tip size for the desired droplet size, application speeds, target rates, and system pressures. Refer to the tables in the *Tip Selection and Application Speed Guide* section on page 105.
2. Use wide-angle spray tips and appropriate spray tip height to achieve approximately 150% pattern overlap.
 - a. When using 80° spray tips:
 - 20" spacing have a minimum spray tip height of 36" [91.4 cm]
 - 15" spacing have a minimum spray tip height of 27" [68.6 cm]
 - 10" spacing have a minimum spray tip height of 18" [45.7 cm]
 - b. When using 110° spray tips:
 - 20" spacing have a minimum spray tip height of 21" [53.3 cm]
 - 15" spacing have a minimum spray tip height of 16" [40.6 cm]
 - 10" spacing have a minimum spray tip height of 10" [25.4 cm]
3. Maintain a system pressure sufficient to fully develop the intended tip spray pattern.
4. To ensure uniform spray coverage when using only pulsing NCVs, avoid operating NCVs below 40% duty cycle when driving straight. During a turn, avoid operating NCVs below 25% duty cycle.
 - a. Stay within the displayed speed range for a selected tip size, application rate, and pressure.
 - b. Avoid application speeds in the bottom 1/3 of the recommended speed range.
 - c. Avoid target flow rates in the bottom 1/3 of the recommended application rate range for each spray tip.
 - d. When turn compensation is active, make gradual turns to avoid operating the NCVs at their limits.
5. Target application rates, speeds, tip sizes, and operating pressures so the NCVs operate at approximately 70% ± 10% duty cycle on average.

FOR EXAMPLE:

Consistent and even field coverage should result under the following application conditions:

- applicator with 20 inch [50.8 cm] NCV spacing
- 110° fan spray tips at 50 PSI [344.7 kPa]
- application speed of 15 mph [24.1 kph]
- spray tip height of 21 inches [53.3 cm]

FIGURE 1. Alternating Spray Pattern and Even Area Coverage

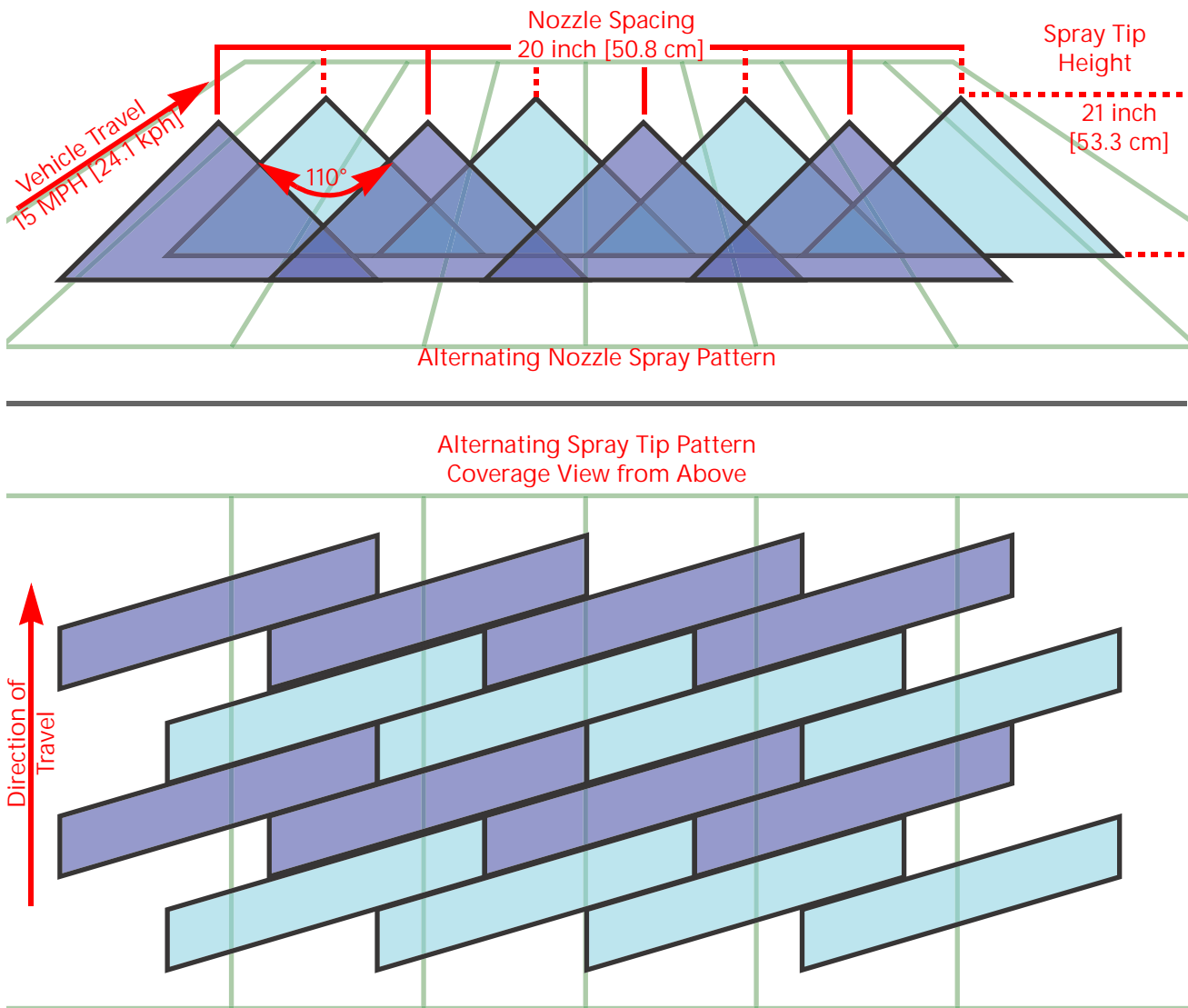

NOTE: In Automatic control mode, the Hawkeye® 2 nozzle control system will adjust the system to maintain the optimal application coverage within the operational ranges provided in the *Tip Selection and Application Speed Guide* section on page 105.

CAUSES OF SKIPS USING HAWKEYE® 2 NOZZLE CONTROL

Operating the Hawkeye® 2 nozzle control system at or outside of the recommended operational ranges may result in under-application or banding.

FOR EXAMPLE:

Under-application or horizontal banding may be observed if the operator from the previous example were to toggle the application mode from Automatic to Manual and then increase the application speed from 15 mph [24.1 kph] to 22 mph [35.4 kph] without manually increasing the nozzle control valve duty cycle.

FIGURE 2. Conditions Resulting in Under-Application and Horizontal Banding

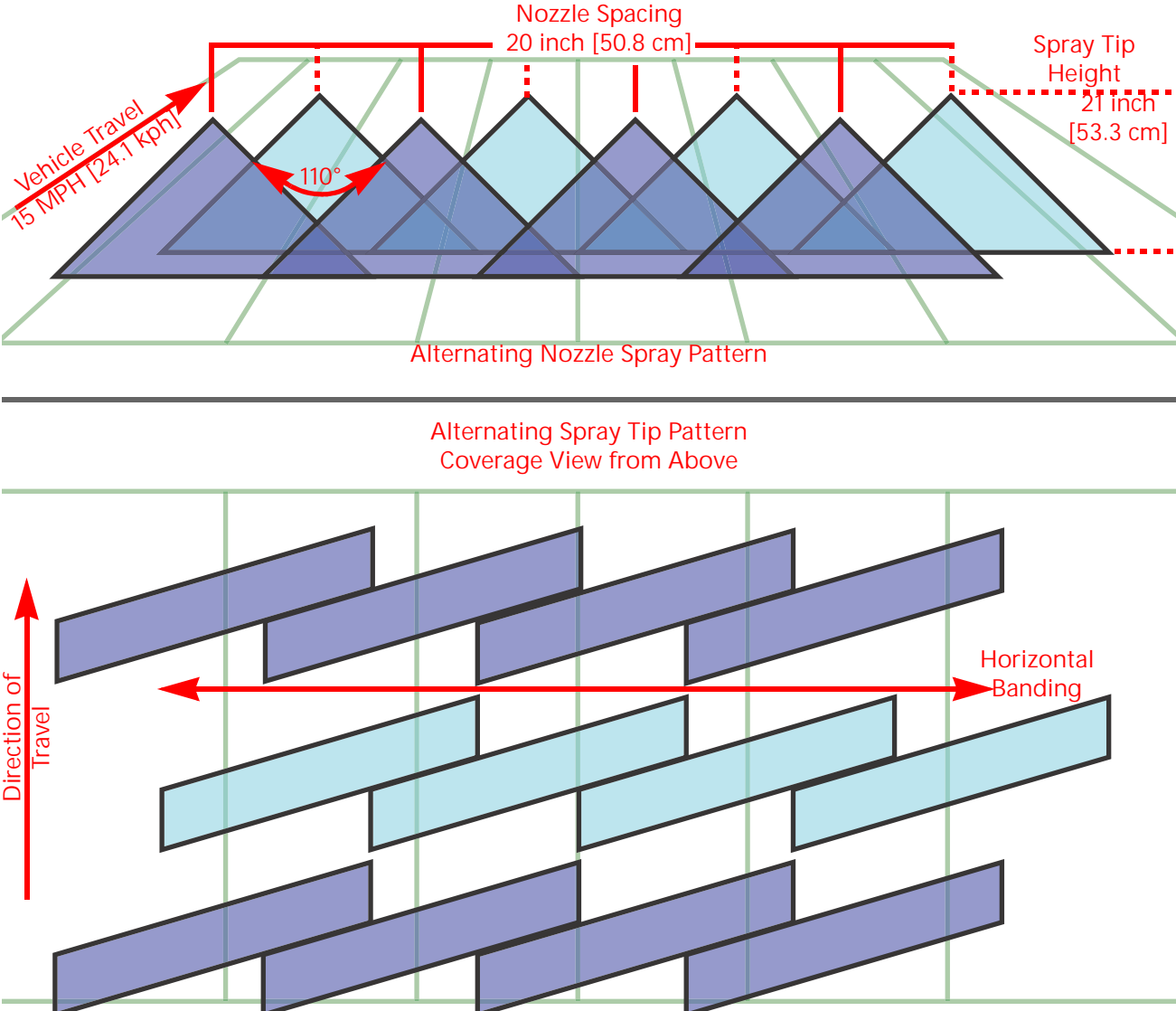

FOR EXAMPLE:

Under-application with diagonal banding may be observed if the following modification to the initial example are made:

- Using 80° fan spray tips at a height of 21 inches [53.3 cm].
- Boom pressure is too low resulting in the NCV tip not being able to achieve full spray pattern.

NOTE: Refer to *Recommendations for Hawkeye® 2 Nozzle Control Operation* section on page 101 and recall the recommended spray height for 80° spray tips. Refer to *Tip Selection and Application Speed Guide* section on page 105 for boom and spray tip pressure recommendations.

FIGURE 3. Conditions Resulting in Under Application and Diagonal Banding

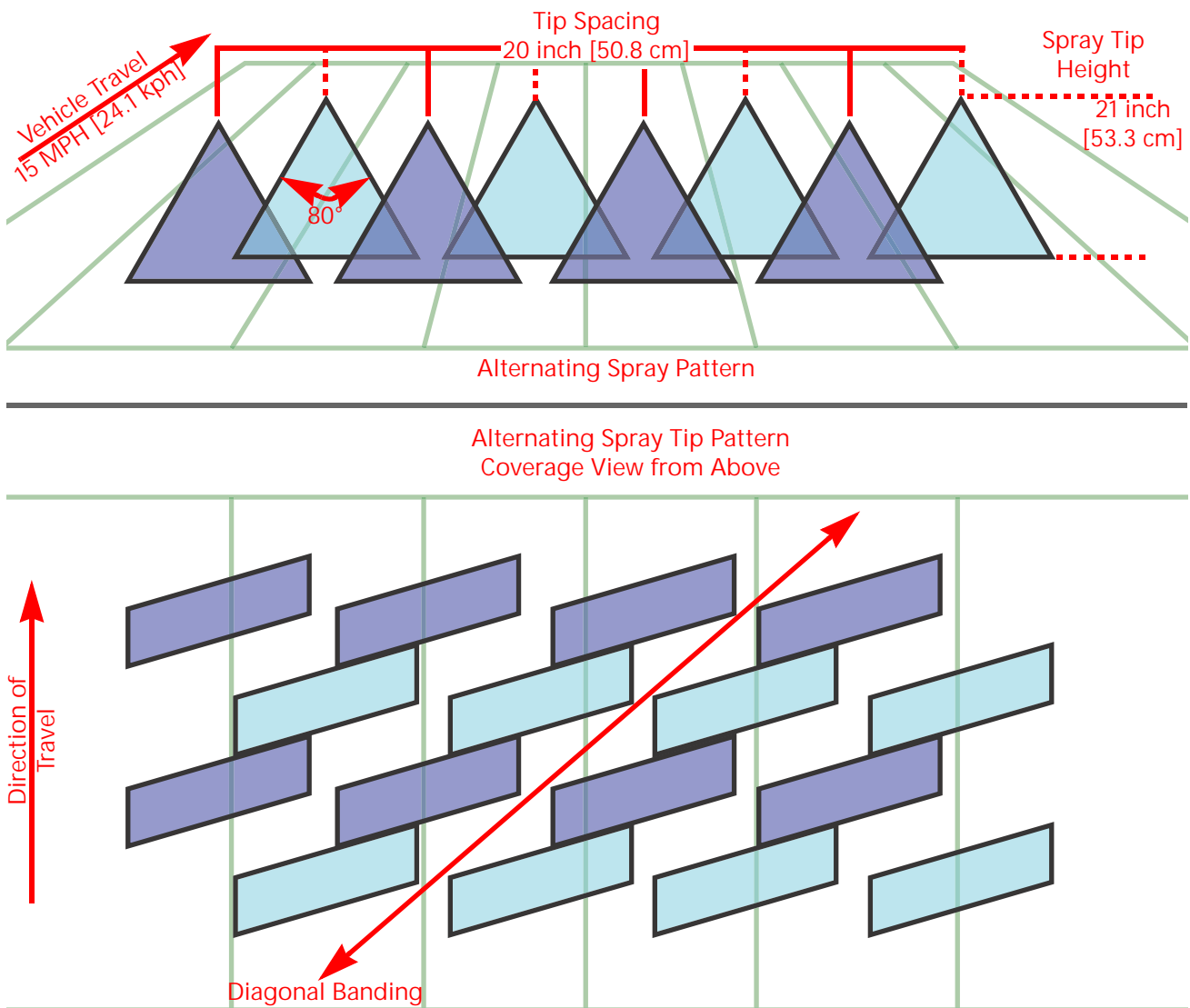

TIP SELECTION AND APPLICATION SPEED GUIDE

DROPLET SIZING

The table below shows the droplet size specifications for different spray tip manufacturers. Use this information when selecting the appropriate spray tips for your application.

To properly size spray tip and type, determine the typical spray speed, target pressure desired for droplet size, and target rate for application.

NOTE: The following tables are common examples. Please refer to the latest spray tip information available from the tip manufacturer for specific applications, compatibility with PWM control technology, and droplet size information.

FOR EXAMPLE:

If the desired target rate is 10 GPA at 15 mph with a medium desired droplet size:

- For conventional spraying, the tip chart recommends using an 05 spray tip at 40 PSI.
- For pulsing NCVs with a target of 70% ± 10% duty cycle, use a 06 or 08 tip. At 40 PSI either tip would create the desired droplet size.

NOTE: Refer to the tip manufacturer for latest information.

Refer to this key while using the example spray tip droplet size table:

TABLE 1. Droplet Size Key

Droplet Size Category	Symbol and Color
Extremely Fine	XF
Very Fine	VF
Fine	F
Medium	M
Coarse	C
Very Coarse	VC
Extremely Coarse	XC
Ultra Coarse	UC

TABLE 2. Example Spray Tip Droplet Size by Manufacturer (Cont'd on Next Page)

Tip Size	Boom Pressure (PSI)	Wilger (www.wilger.net)				TeeJet (www.teejet.com)			Hypro (www.hypropumps.com)				
		ER	SR	MR	DR	XR/XRC	TT/2XTT	TT160	HF	GRD	LD	VP	TR
	Gauge	110	110	110	110	110	110	110	110	110	110	110	120
03	20	M	-	C	-	M	VC	VC	-	M	M	F	M
	30	M	C	VC	XC	F	C	C	-	M	M	F	F
	40	F	C	VC	XC	F	C	C	-	M	M	F	F
	50	F	C	C	VC	F	M	C	-	M	M	F	F
	60	F	C	C	VC	F	M	C	-	M	M	F	F

Tip Size	Boom Pressure (PSI)	Wilger (www.wilger.net)				TeeJet (www.teejet.com)			Hypro (www.hypropumps.com)				
Orifice Size	PSI	ER	SR	MR	DR	XR/XRC	TT/2XTT	TTJ60	HF	GRD	LD	VP	TR
	Gauge	110	110	110	110	110	110	110	110	110	110	110	120
04	20	C	-	-	-	M	VC	VC	-	C	C	M	M
	30	C	C	VC	XC	M	C	C	-	C	C	M	M
	40	M	C	VC	XC	M	C	C	-	C	M	F	F
	50	M	C	C	XC	F	M	C	-	M	M	F	F
	60	M	C	C	VC	F	M	C	-	M	M	F	F
05	20	C	-	-	-	M	VC	VC	-	C	C	M	C
	30	C	VC	XC	XC	M	VC	C	-	C	C	M	M
	40	M	C	XC	XC	M	C	C	-	C	M	F	F
	50	M	C	VC	XC	F	C	C	-	M	M	F	F
	60	M	C	VC	XC	F	M	C	-	C	C	F	M
06	20	C	-	-	-	M	VC	XC	-	VC	VC	M	C
	30	C	VC	XC	XC	M	VC	VC	-	C	C	M	C
	40	C	VC	XC	XC	M	VC	C	-	C	C	M	M
	50	C	C	XC	XC	M	C	C	-	C	C	F	M
	60	C	C	VC	XC	F	C	C	-	C	C	F	M
08	20	C	-	-	-	C	VC	-	UC	VC	VC	C	C
	30	C	XC	XC	XC	C	VC	-	UC	C	C	M	C
	40	C	VC	XC	XC	M	C	-	UC	C	C	M	M
	50	C	VC	XC	XC	M	C	-	UC	C	C	M	M
	60	C	C	VC	XC	M	C	-	XC	C	C	M	M
10	30	C	XC	XC	UC	C	-	-	UC	-	-	C	VC
	40	C	VC	XC	UC	M	-	-	UC	-	-	C	C
	50	C	VC	XC	XC	M	-	-	UC	-	-	M	M
	60	C	VC	VC	XC	M	-	-	XC	-	-	M	M
12.5	40	VC	VC	XC	XC	-	-	-	-	-	-	-	-
	50	C	VC	XC	XC	-	-	-	-	-	-	-	-
	60	C	VC	XC	XC	-	-	-	-	-	-	-	-
15	40	VC	XC	XC	XC	C	-	-	UC	-	-	VC	VC
	50	C	XC	XC	XC	C	-	-	UC	-	-	C	C
	60	C	XC	XC	XC	C	-	-	XC	-	-	M	M

APPLICATION SPEED GUIDE

The ranges for speed and flow rate provided in this section are for reference purposes only. Observed ranges may vary depending upon application system plumbing and hardware. It is recommended to avoid operating at, or close to, the upper and lower limits of the speed or flow rate ranges shown for each spray tip. The values in the following tables are based on 15" and 20" nozzle spacing.

Review the following information before proceeding to the tables on the following pages:

- Operating speeds and ranges below 0.5mph and above 30mph are not shown.
- For best coverage, target application rates, pressures, operating speeds, and tip sizes for 70% (+/- 10%) average NCV duty cycle when driving straight in the field, and still allow for some periodic speed adjustment and turn compensation.
- Avoid tip sizes and speeds resulting in average NCV duty cycle below 40% for contact/coverage sensitive products.
- 25% duty cycle operation should be avoided, except when conducting a turn.
- Consider adjusting tip sizes or operating speeds if consistently operating at or near 100% of the average NCV duty cycle in PWM pulsing modes.
- Use Bypass, High Flow, or Tiered Nozzle modes for target application rates above 20 GPA [190 l/ha] or target flow rates over 1.4 GPM [5.3 l/min] per tip.
- Tip sizes below 02 and above 15 are not recommended for use on NCVs. As spray tip sizes decrease, actual speed range decreases and tip plugging is more likely. As spray tip sizes increase, full-tip flow will not be achieved due to the flow limitations of NCVs.
- Overall speed ranges displayed on the UT are less than the speed ranges (in ideal conditions) displayed in the tables on the following pages. This is to ensure operation within the capabilities of the system.
- Table speeds are based on water-based carrier products. Changing to fertilizer-based products (which are more dense) will decrease the minimum and maximum flow values displayed on the UT.
- Table speeds are based on 100% NCV efficiency. Higher or lower efficiencies will increase or decrease the overall speed range on the UT.
- Table speeds do not account for any minimum and maximum flow offsets applied to individual NCVs.

TABLE 6. Speed Table for Tiered Nozzle (NCV + Electronic Bypass Nozzle) Mode - 20" Spacing

RECOMMENDED TIP SIZE		TIERED NOZZLE MODE SPEED RANGE (MPH) 20" Inch Spacing																						
		5 GPA		10 GPA		15 GPA		20 GPA		25 GPA		30 GPA		40 GPA		50 GPA		60 GPA						
NCV	AUX	NCV (25%)	NCV (100%)	NCV (<->)	AUX	NCV (25%)	NCV (100%)	NCV (<->)	AUX	NCV (25%)	NCV (100%)	NCV (<->)	AUX	NCV (25%)	NCV (100%)	NCV (<->)	AUX	NCV (25%)	NCV (100%)	NCV (<->)	AUX			
02	01	20 2.1 8.2 12.6	20 1.0 4.1 6.3	20 0.7 2.7 4.2	20 0.5 3.2 4.2	20 0.6 2.5 3.8	20 0.7 2.9 4.4	20 0.8 3.3 5.0	20 0.7 2.6 4.0	20 0.6 2.4 3.6	20 0.4 1.6 2.5	20 0.3 1.4 2.1	20 0.4 1.7 2.6	20 0.5 1.9 3.0	20 0.4 1.5 2.2	20 0.4 1.6 2.5	20 0.4 1.8 2.7	20 0.4 1.8 2.7	20 0.3 1.3 2.1	20 0.4 1.6 2.6	20 0.5 1.8 3.0	20 0.4 1.7 2.7	20 0.5 1.8 2.9	
025	015	30 2.6 10.4 17.0	30 1.6 6.4 10.4	30 1.1 4.3 6.9	30 0.8 3.2 5.2	30 0.9 3.7 6.0	30 1.0 4.1 6.7	30 1.1 4.5 7.3	30 0.9 3.6 5.9	30 0.8 3.0 4.9	30 0.6 2.5 4.2	30 0.5 2.1 3.5	30 0.6 2.5 4.3	30 0.7 2.9 4.9	30 0.6 2.5 4.1	30 0.5 2.1 3.3	30 0.5 2.1 3.3	30 0.6 2.3 3.7	30 0.4 1.6 2.6	30 0.5 1.9 3.2	30 0.6 2.3 3.8	30 0.5 1.9 3.2	30 0.4 1.5 2.4	30 0.5 1.8 2.9
03	02	40 2.9 11.6 19.1	40 1.8 7.4 12.0	40 1.2 4.9 8.0	40 0.9 3.7 6.0	40 1.1 4.4 7.4	40 1.2 4.9 8.2	40 1.3 5.2 8.5	40 1.0 4.1 6.7	40 0.9 3.6 5.9	40 0.6 2.5 4.2	40 0.5 2.1 3.5	40 0.6 2.5 4.3	40 0.7 2.9 4.9	40 0.6 2.5 4.1	40 0.5 2.1 3.3	40 0.5 2.1 3.3	40 0.6 2.3 3.7	40 0.4 1.6 2.6	40 0.5 1.9 3.2	40 0.6 2.3 3.8	40 0.5 1.9 3.2	40 0.4 1.5 2.4	40 0.5 1.8 2.9
04	025	50 3.2 13.0 21.4	50 2.3 9.0 14.6	50 1.5 6.0 9.8	50 1.1 4.5 7.3	50 1.1 4.5 7.3	50 1.2 4.9 8.2	50 1.3 5.2 8.5	50 1.0 4.1 6.7	50 0.9 3.6 5.9	50 0.6 2.5 4.2	50 0.5 2.1 3.5	50 0.6 2.5 4.3	50 0.7 2.9 4.9	50 0.6 2.5 4.1	50 0.5 2.1 3.3	50 0.5 2.1 3.3	50 0.6 2.3 3.7	50 0.4 1.6 2.6	50 0.5 1.9 3.2	50 0.6 2.3 3.8	50 0.5 1.9 3.2	50 0.4 1.5 2.4	50 0.5 1.8 2.9
05	03	60 2.5 10.1 16.5	60 1.5 6.2 10.4	60 1.0 4.1 7.0	60 0.8 3.1 5.2	60 0.9 3.8 6.4	60 1.1 4.4 7.4	60 1.2 4.9 8.2	60 1.0 4.1 6.7	60 0.9 3.6 5.9	60 0.6 2.5 4.2	60 0.5 2.1 3.5	60 0.6 2.5 4.3	60 0.7 2.9 4.9	60 0.6 2.5 4.1	60 0.5 2.1 3.3	60 0.5 2.1 3.3	60 0.6 2.3 3.7	60 0.4 1.6 2.6	60 0.5 1.9 3.2	60 0.6 2.3 3.8	60 0.5 1.9 3.2	60 0.4 1.5 2.4	60 0.5 1.8 2.9
06	04	20 2.5 10.1 16.5	20 1.5 6.2 10.4	20 1.0 4.1 7.0	20 0.8 3.1 5.2	20 0.9 3.8 6.4	20 1.1 4.4 7.4	20 1.2 4.9 8.2	20 1.0 4.1 6.7	20 0.9 3.6 5.9	20 0.6 2.5 4.2	20 0.5 2.1 3.5	20 0.6 2.5 4.3	20 0.7 2.9 4.9	20 0.6 2.5 4.1	20 0.5 2.1 3.3	20 0.5 2.1 3.3	20 0.6 2.3 3.7	20 0.4 1.6 2.6	20 0.5 1.9 3.2	20 0.6 2.3 3.8	20 0.5 1.9 3.2	20 0.4 1.5 2.4	20 0.5 1.8 2.9
08	05	30 3.1 12.4 20.2	30 2.2 8.8 14.7	30 1.5 6.0 9.8	30 1.1 4.5 7.3	30 1.1 4.5 7.3	30 1.2 4.9 8.2	30 1.3 5.2 8.5	30 1.0 4.1 6.7	30 0.9 3.6 5.9	30 0.6 2.5 4.2	30 0.5 2.1 3.5	30 0.6 2.5 4.3	30 0.7 2.9 4.9	30 0.6 2.5 4.1	30 0.5 2.1 3.3	30 0.5 2.1 3.3	30 0.6 2.3 3.7	30 0.4 1.6 2.6	30 0.5 1.9 3.2	30 0.6 2.3 3.8	30 0.5 1.9 3.2	30 0.4 1.5 2.4	30 0.5 1.8 2.9
10	06	40 2.9 11.7 19.0	40 1.8 7.4 12.0	40 1.2 4.9 8.0	40 0.9 3.7 6.0	40 1.1 4.4 7.4	40 1.2 4.9 8.2	40 1.3 5.2 8.5	40 1.0 4.1 6.7	40 0.9 3.6 5.9	40 0.6 2.5 4.2	40 0.5 2.1 3.5	40 0.6 2.5 4.3	40 0.7 2.9 4.9	40 0.6 2.5 4.1	40 0.5 2.1 3.3	40 0.5 2.1 3.3	40 0.6 2.3 3.7	40 0.4 1.6 2.6	40 0.5 1.9 3.2	40 0.6 2.3 3.8	40 0.5 1.9 3.2	40 0.4 1.5 2.4	40 0.5 1.8 2.9
15	08	50 2.9 11.7 19.0	50 1.8 7.4 12.0	50 1.2 4.9 8.0	50 0.9 3.7 6.0	50 1.1 4.4 7.4	50 1.2 4.9 8.2	50 1.3 5.2 8.5	50 1.0 4.1 6.7	50 0.9 3.6 5.9	50 0.6 2.5 4.2	50 0.5 2.1 3.5	50 0.6 2.5 4.3	50 0.7 2.9 4.9	50 0.6 2.5 4.1	50 0.5 2.1 3.3	50 0.5 2.1 3.3	50 0.6 2.3 3.7	50 0.4 1.6 2.6	50 0.5 1.9 3.2	50 0.6 2.3 3.8	50 0.5 1.9 3.2	50 0.4 1.5 2.4	50 0.5 1.8 2.9
125	06	60 2.6 10.2 17.3	60 1.6 6.4 10.4	60 1.1 4.3 6.9	60 0.8 3.2 5.2	60 0.9 3.7 6.0	60 1.0 4.1 6.7	60 1.1 4.5 7.3	60 0.9 3.6 5.9	60 0.8 3.0 4.9	60 0.6 2.5 4.2	60 0.5 2.1 3.5	60 0.6 2.5 4.3	60 0.7 2.9 4.9	60 0.6 2.5 4.1	60 0.5 2.1 3.3	60 0.5 2.1 3.3	60 0.6 2.3 3.7	60 0.4 1.6 2.6	60 0.5 1.9 3.2	60 0.6 2.3 3.8	60 0.5 1.9 3.2	60 0.4 1.5 2.4	60 0.5 1.8 2.9
		60 3.1 12.2 20.7	60 2.3 9.0 14.6	60 1.5 6.0 9.8	60 1.1 4.5 7.3	60 1.1 4.5 7.3	60 1.2 4.9 8.2	60 1.3 5.2 8.5	60 1.0 4.1 6.7	60 0.9 3.6 5.9	60 0.6 2.5 4.2	60 0.5 2.1 3.5	60 0.6 2.5 4.3	60 0.7 2.9 4.9	60 0.6 2.5 4.1	60 0.5 2.1 3.3	60 0.5 2.1 3.3	60 0.6 2.3 3.7	60 0.4 1.6 2.6	60 0.5 1.9 3.2	60 0.6 2.3 3.8	60 0.5 1.9 3.2	60 0.4 1.5 2.4	60 0.5 1.8 2.9

B

SECTION WIDTHS

Use the following formulas to help calculate the section widths.

Calculate the section width with the formula:

$$T \times S = SW$$

Where T = the number of Tips in each section, S = the Spacing between tips, and SW = the Section Width.

FOR EXAMPLE:

7 tips in a section with spacing of 20 inches [50.8 cm] would yield:

$$7 \times 20 = 140$$

or a Section Width of 140 inches [356 cm]. Enter 140 [356] as the width for this section. (EQ 1)

TARGET RATE CALIBRATION

The following information must be known in order to determine which spray nozzles to use with the sprayer:

- Nominal Application Pressure _____ PSI [kpa]
- Target Application Rate _____ GPA [L/ha]
- Target Speed _____ MPH [kph]
- Nozzle Spacing _____ inches [cm]

From this information, calculate the volume per minute per nozzle as follows:

$$NVPM = \frac{\text{Rate} \times \text{Speed} \times \text{NS}}{5,940[60,000]}$$

NVPM = Nozzle Volume per Minute (Gal/Min [L/Min]), Rate = Target Application Rate, Speed = Target Speed of Application, and NS = Nozzle Spacing.

FOR EXAMPLE:

Application Pressure = 30 PSI, Target Application Rate = 20 GPA, Target Speed = 5.2 MPH, and Nozzle Spacing = 20 inches

$$NVPM = \frac{20 \times 5.2 \times 20}{5,940} = 0.35$$

Using the calculated nozzle volume per minute of 0.35 at an application pressure of 30, select a boom nozzle which comes closest to providing the desired output.

PRODUCT CALIBRATION SETTINGS

Review the *Control Valve Settings and Tuning* section on page 27 for assistance with calibrating and tuning the product control valve.

FLOW METER RE-CALIBRATION

1. Enter a meter cal number of 10 [38].
2. Enter a total volume of 0.
3. Switch all booms off.
4. Remove a boom hose and place it in a calibrated 5 gallon [19 liter] container.
5. Turn on the boom and master switches.
6. Pump exactly 10 gallons [38 liters].
7. The readout in total volume is the new meter cal number. This number should be within $\pm 3\%$ of the number stamped of the flow meter tag.
8. Zero out the total volume.
9. Repeat the calibration procedure several times to confirm the reading accuracy.

NOTE: For greatest precision, set the meter cal to 100 [378 liters] and pump 100 gallons [378 liters] of water.

10. To verify the flow meter calibration, fill the applicator tank with a predetermined amount of measured liquid (e.g. 250 gallons [946.4 L]). Do not rely on the graduation numbers molded into the applicator tank. Empty the applicator tank under normal operating conditions. If the number displayed under the total volume is different from the predetermined amount of measured liquid by more than $\pm 3\%$, complete the following calculation.

FOR EXAMPLE: A meter cal of 720 [190], total volume of 260 [983], and a predetermined amount of measured liquid equaling 250 [946]:

US Units:

$$\text{CorrectedMeterCal} = \frac{\text{MeterCal} \times \text{TotalVolume}}{\text{MeasuredVolume}} = \frac{720 \times 260}{250} = 748.8$$

Metric Units:

$$\text{CorrectedMeterCal} = \frac{\text{MeterCal} \times \text{TotalVolume}}{\text{MeasuredVolume}} = \frac{[190] \times [983]}{[946]} = 197.4$$

Enter a corrected meter cal of 749 [198].

11. Enter the corrected meter cal before resuming application.

SPECIFICATIONS BASED ON WATER

Flow Meter Size	RFM 15P (M200) Flange	RFM 60P (M200) Flange	RFM 100P (M220) Flange	RFM 200P (M300) Flange
Pressure Rating	175 psi [1206.6 kPa]	175 psi [1206.6 kPa]	150 psi [1034.2 kPa]	125 psi [861.8 kPa]
Normal Flow Range	0.5 - 15 GPM [1.9 - 56.8 L/min]	1.5 - 60 GPM [5.7 - 227.1 L/min]	3 - 100 GPM [11.4 - 378.5 L/min]	15 - 200 GPM [56.8 - 757.1 L/min]
Pressure Drop	3 psi @ 15 GPM [20.7 kPa @ 56.8 L/min]	5 psi @ 60 GPM [34.5 kPa @ 227.1 L/min]	3 psi @ 100 GPM [20.7 kPa @ 378.5 L/min]	4 psi @ 200 GPM [27.6 kPa @ 757.1 L/min]
Max Flow Range ¹	0.5 - 40 GPM [1.9 - 151.4 L/min]	1.5 - 150 GPM [5.7 - 567.8 L/min]	3 - 250 GPM [11.4 - 946.4 L/min]	15 - 320 GPM [56.8 - 1211.3 L/min]
Pressure Drop	15 psi @ 40 GPM [103.4 kPa @ 151.4 L/min]	35 psi @ 150 GPM [241.3 kPa @ 567.8 L/min]	16 psi @ 250GPM [110.3 kPa @ 946.4 L/min]	9 psi @ 320 GPM [62.1 kPa @ 1211.3 L/min]

1. May reduce flow meter service life.

SYSTEM MAINTENANCE

TABLE 1. Maintenance Schedule

Inspection	Frequency	Procedure
System Rinse	Daily after use	<ol style="list-style-type: none"> 1. Ensure the main product tank is cleaned and filled with at least 100 gallons of fresh water or that the pump is drawing fresh water from the vehicle rinse tank. 2. Park the sprayer in a safe location to unfold the booms and spray. 3. Ensure the RCM - Sprayer product control mode is set to Auto. 4. Enter a target pressure of 40-60 psi [275.8 - 413.7 kPa] (for applicable NCV control modes) and an application rate of 10-20 GPA [93.5 - 187.1 L/ha]. 5. Set the test speed to 6 mph [9.7 km/h]. 6. Enable the sprayer product pump. 7. Turn on all section switches and the master spray switch. 8. Continue to spray water out of the booms until all chemical is flushed from the system or at least 30 seconds. 9. Turn off the Master Spray Switch.
System Rinse (for sprayers equipped with Air Blow Out systems)	Daily after use	<ol style="list-style-type: none"> 1. Perform a system rinse. 2. Set the Hawkeye® 2 system to Manual mode. 3. Set the pump PWM to zero and NCV PWM to 50-75%. 4. Follow the vehicle manufacturer's normal procedure for the Air Blow-Out function.

Inspection	Frequency	Procedure
Walk-Around Inspection of System Cables and Components	Weekly/as needed	<ol style="list-style-type: none"> 1. With the system power on, ensure all installed Hawkeye® 2 NCV LEDs are flashing. If not, check the cable connections to the NCVs and the fuses in the fuse block located near the boom on the chassis cable harness. 2. Verify the boom cables are securely fastened to the boom and are not hanging below the lower boom tube. 3. Inspect each NCV for damage and proper installation on the nozzle bodies. 4. Verify that the Hawkeye® 2 CANbus terminators (located on the boom cables on each boom tip) are present and securely tied to the boom cables. 5. Inspect system cables, sensor cables, connections, fuses, and relays for trapped moisture, corrosion, stretching, or other signs of potential damage. Repair or replace as needed. <p>Systems that have significant debris or product buildup, and those that are cleaned with high pressure water often may require more diligent inspection.</p>
NCV Seal Replacement	After 500 hours or as needed. Inspect both before and after spray season.	<ol style="list-style-type: none"> 1. Turn off the Hawkeye® 2 system and product pump. 2. Bleed any remaining pressure from the boom system. 3. Perform the Nozzle Control Valve maintenance procedure (page 122).

FIGURE 1. Service Parts (reference tables below for detail)

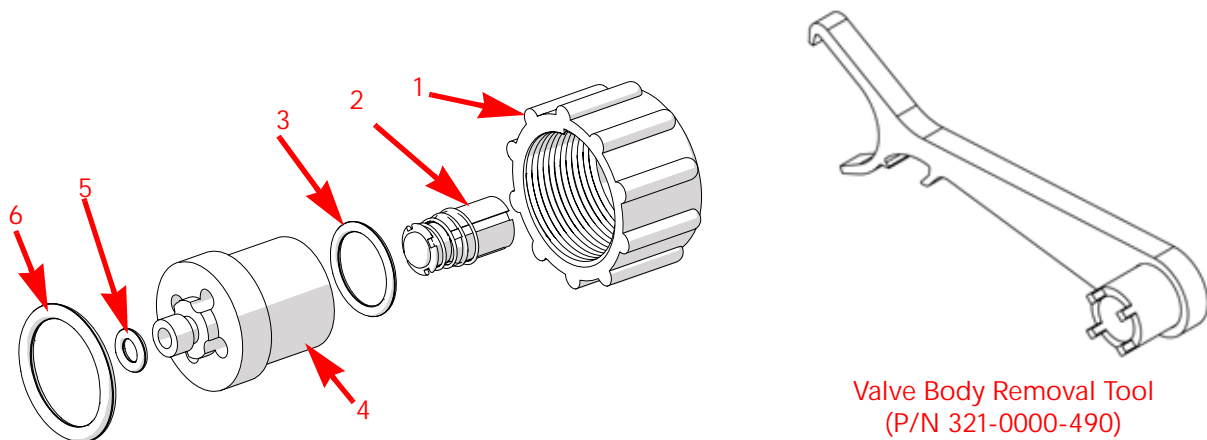

TABLE 2. Hypro/Arag Nozzle Control Valve (P/N 063-2005-002) Service Parts

Item	Description	Part Number
1	Fly Nut (x100)	117-1005-214
2	Plunger Assembly	N/A
3	O-Ring	N/A
4	Stainless Valve Body	107-1005-003
5	Outlet Seal (Qty. 38)	219-2005-001M
6	O-Ring (Qty. 38)	219-2005-115M
2, 3, 5, 6	Replacement Seal Kit (x100)	117-2005-065
1, 2, 3, 5, 6	Single NCV Seal Replacement Kit (x1)	117-2005-061

TABLE 3. Hypro/Arag System Service Kit (P/N 117-2005-051) Includes:

Description	Qty	Part Number
NCV, Hypro/Arag Hawkeye	1	063-2005-002
Kit, Hypro/Arag Hawkeye Valve Seal	3	117-2005-061
Cable, 8-Pin Ampseal	2	115-2005-070
O-ring, Blue Coated Size -115 Single Viton™	1	219-2005-115
Tool, Hawkeye Valve	2	321-0000-490

TABLE 4. TeeJet Nozzle Control Valve (P/N 063-2005-001) Service Parts

Item	Description	Part Number
1	Fly Nut (x100)	117-1005-213
2	Plunger Assembly	N/A
3	O-Ring	N/A
4	Stainless Valve Body	107-1005-001
5	Outlet Seal (Qty. 38)	219-2005-001M
6	O-Ring, Blue (Qty. 38)	219-2005-115M
6	O-Ring, Black (Qty. 38)	219-2005-116M
2, 3, 5, 6	Replacement Seal Kit (x100)	117-2005-064
1, 2, 3, 5, 6	Single NCV Seal Replacement Kit (x1)	117-2005-060

TABLE 5. TeeJet System Service Kit (P/N 117-2005-050) Includes:

Description	Qty.	Part Number
NCV, TeeJet Hawkeye	1	063-2005-001
Kit, TeeJet Hawkeye Valve Seal	3	117-2005-060
Cable, 8-Pin Ampseal	2	115-2005-070
O-Ring, Blue Coated Size -115 Single Viton™	1	219-2005-115
O-Ring, Black Size - 116 Single Viton™	1	219-2005-116
Tool, Hawkeye Valve	2	321-0000-490

TABLE 6. Wilger Nozzle Control Valve (P/N 063-2005-003) Service Parts

Item	Description	Part Number
1	Fly Nut (x100)	117-1005-215
2	Plunger Assembly	N/A
3	O-Ring	N/A
4	Stainless Valve Body	107-1005-002
5	Outlet Seal (Qty. 38)	219-2005-002M
6	O-Ring (Qty. 38)	219-2005-116M
2, 3, 5, 6	Replacement Seal Kit (x100)	117-2005-066
1, 2, 3, 5, 6	Single NCV Seal Replacement Kit (x1).	117-2005-062

TABLE 7. Wilger System Service Kit (P/N 117-2005-052) Includes:

Description	Qty.	Part Number
NCV, Wilger Hawkeye	1	063-2005-003
Kit, Wilger Hawkeye Valve Seal	3	117-2005-052
Cable, 8-Pin Ampseal	2	115-2005-070
O-Ring, Black Size - 116 Single Viton™	1	219-2005-116
Tool, Hawkeye Valve	2	321-0000-490

NOZZLE CONTROL VALVE MAINTENANCE PROCEDURE

Hawkeye® 2 nozzle control valves are designed to provide maintenance free operation with proper equipment maintenance as recommended by the equipment or chemical manufacturer. However, the seals may become worn or swollen due to chemical compounds, chemical formulations, or high operating pressures. This may cause accelerated wear to the sealing surfaces. The following nozzle control valve maintenance procedures should be performed on the nozzle control system or on individual NCVs if leaks are observed at a specific spray tip.

FIGURE 2. Nozzle Control Valve Maintenance Detail

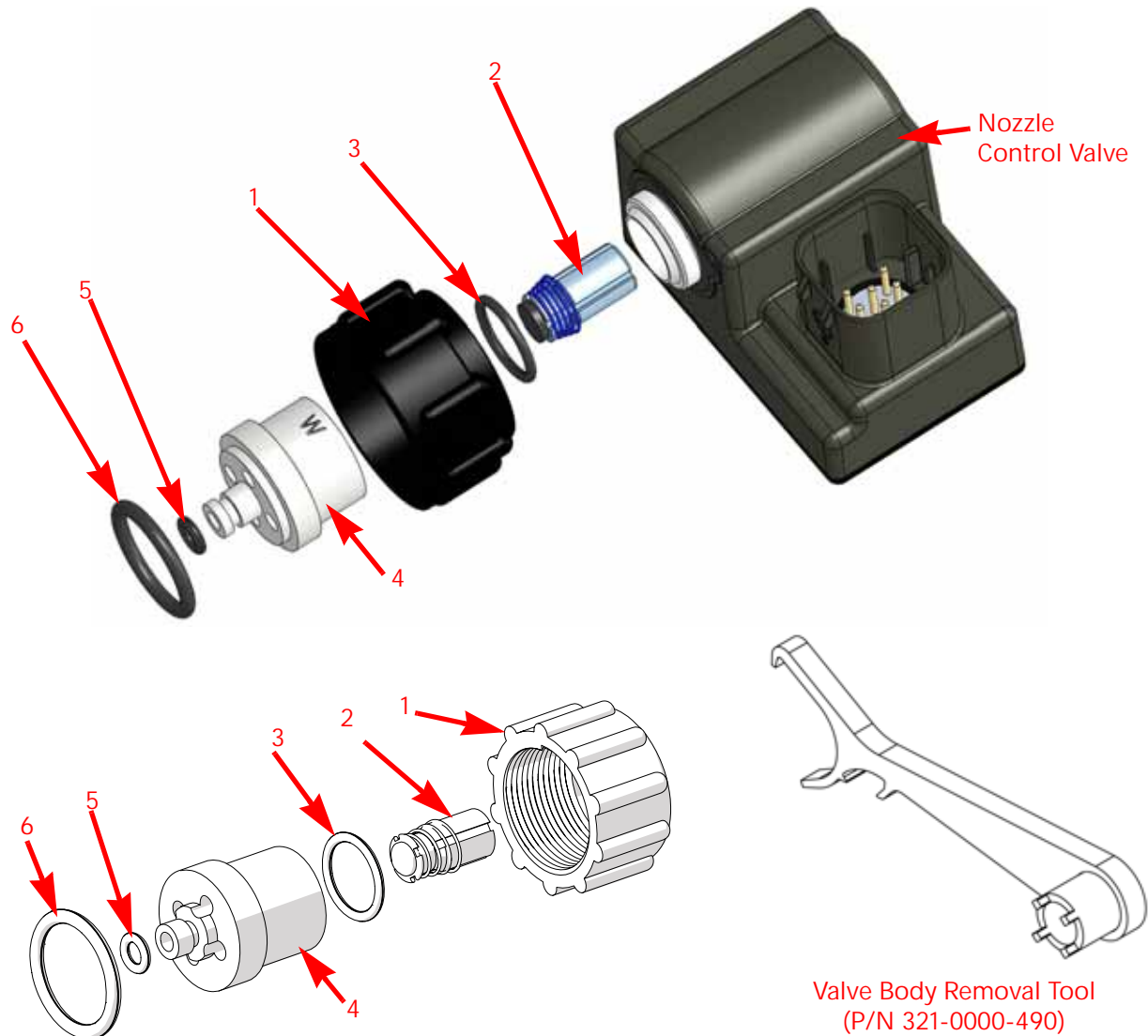

1. Loosen the fly nut (item 1) and remove the Hawkeye® 2 nozzle control valve from the nozzle body.
2. Inspect the large o-ring (item 6) on the face of the valve body (item 4). Replace if necessary.
3. Inspect the small o-ring (item 5) on the tip of the valve body. Replace if necessary.
4. Using a valve body removal tool (P/N 321-0000-457), loosen and remove the valve body (item 4) from the Hawkeye® 2 nozzle control valve.

FIGURE 3. Nozzle Control Valve Exploded View

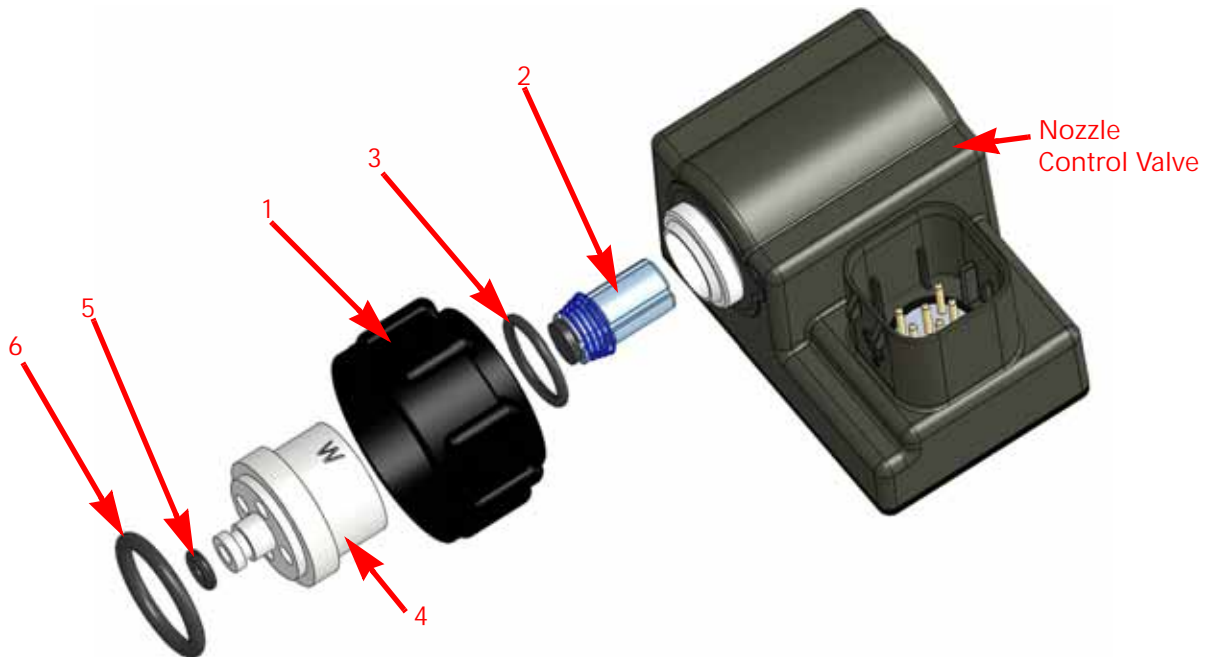

5. Inspect the o-ring (item 3) on the inside of the valve body. Replace if necessary.
6. Clean and inspect the plunger assembly (item 2). Replace the plunger assembly if the rubber seal is worn or damaged. Refer to Figure 4 on page 123 for reference to plunger seal condition.
7. Inspect fly nut (item 1). Replace if worn or damaged.

FIGURE 4. Plunger Inspection Detail



NOTE: Extreme duty poppet kits are available.

- P/N 117-1005-216 - Teejet
- P/N 117-1005-217 - Hypro/Arag
- P/N 117-1005-218 - Wilger

Seal color may vary.

HAWKEYE® 2 NOZZLE CONTROL VALVE ASSEMBLY PROCEDURE

To reassemble a nozzle control valve after inspection and maintenance:

FIGURE 5. Nozzle Control Valve Assembly

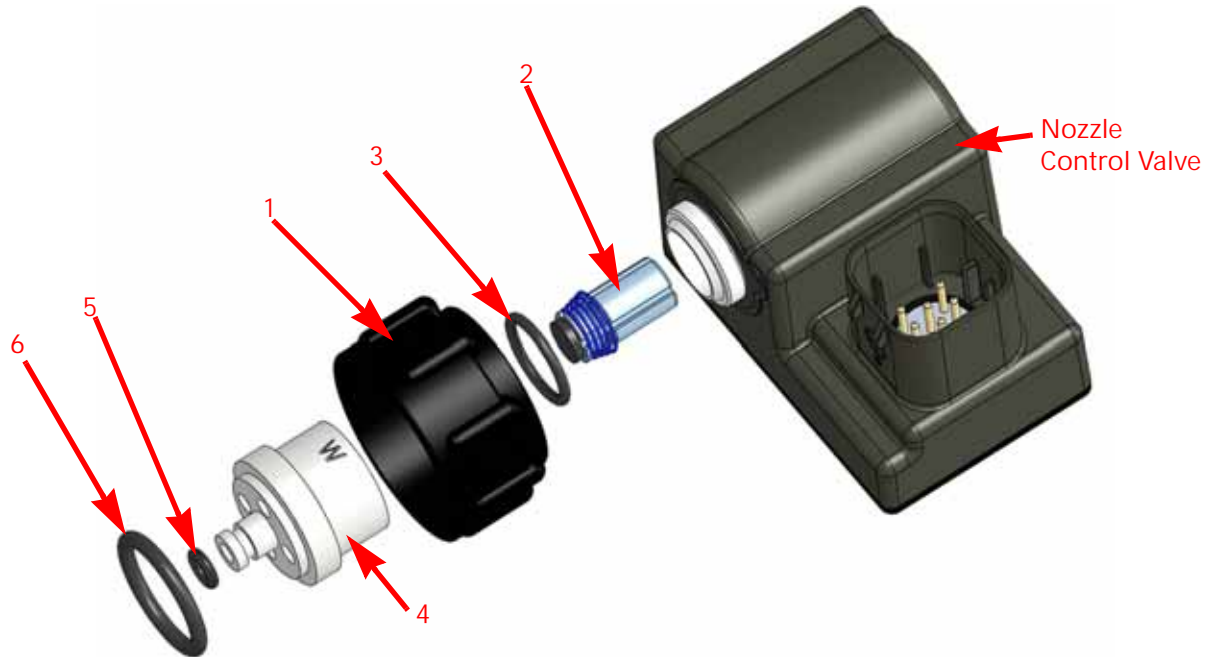

1. Replace fly nut (item 3) over valve body (item 4).
2. Replace o-ring (item 2) inside valve body.
3. Place plunger assembly (item 1) into nozzle control valve cavity.
4. Thread the valve body onto the nozzle control valve and finger tighten.
5. Using a valve body removal tool (P/N 321-0000-457), turn valve body 1/4 to 1/3 turn to secure to the valve body.
6. Verify small o-ring (item 5) is seated into groove on valve body tip.
7. Place large o-ring (item 6) onto valve body face.
8. Thread fly nut onto nozzle body on the spray boom.
9. Hand tighten the fly nut to the nozzle body or use the fly nut wrench if necessary. Do not over tighten.
10. Prior to filling the tank with chemical or starting a field application, refer to the *Testing for Leaks* section on page 125 to test the Hawkeye® 2 system.

SYSTEM TESTING

TESTING FOR LEAKS

NOTE: The mobile app or the Remote Section Control may be helpful when testing system function or testing spray tips and NCVs.

1. Fill the applicator tank with clean water.
2. Toggle the implement master switch to the on position.
3. Select the pump softkey to activate the product pump.
4. Toggle one section switch to the on position.
5. Inspect the Hawkeye® 2 nozzle control valves for leaks around the fly nut.
6. If leaks are observed:
 - a. Toggle the section and master switches to the off position.
 - b. Use the Hawkeye® 2 fly nut wrench to carefully tighten the fly nut until leaking ceases.
 - c. If leaking continues after tightening the fly nut more than half a turn, perform the procedures outlined in the *Nozzle Control Valve Maintenance Procedure* section on page 122 to inspect the nozzle control valve, o-rings, and plunger assembly.
 - d. Repeat this procedure to verify leak has stopped. Contact a local Raven dealer for additional assistance if leaks persist.
7. Repeat this process to check nozzle control valves on each section of the equipment.

FLOW METER MAINTENANCE

NOTE: Remove system pressure and chemical from the hoses and all other system lines prior to disassembling the flow meter, fittings, or hoses.

1. Remove flow meter from the equipment and flush with clean water to remove any chemicals.
2. Remove flange bolts or clamp from the flow meter.
3. Remove the turbine hub and turbine from inside flow meter.
4. Clean turbine and turbine hub of metal filings or any other foreign material, such as wettable powders. Confirm that the turbine blades are not worn. While holding the turbine hub in your hand, spin turbine. The turbine should spin freely with very little drag inside the hub.
5. If transducer assembly is replaced or if turbine stud is adjusted or replaced, verify the turbine fit before reassembling. Hold turbine hub with turbine on transducer. Spin turbine by blowing on it. Tighten turbine stud until turbine stalls. Loosen turbine stud 1/3 turn. The turbine should spin freely.
6. Re-assemble flow meter.
7. Using a low pressure (approximately 5 PSI [34.5 kPa]) jet of air, verify the turbine spins freely. If there is drag, loosen hex stud on the bottom of turbine hub 1/16 turn until the turbine spins freely.
8. If the turbine spins freely and cables have been checked per *Troubleshooting Flow Meter Cables* section on page 97, but flow meter still is not metering properly, replace flow meter transducer.

RECALIBRATING THE FLOW METER

To calibrate the flow meter:

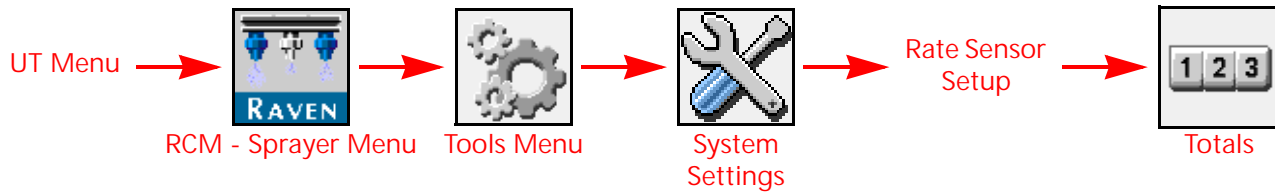

1. Fill the applicator tank with clean water.
2. Open the UT Menu and select the RCM - Sprayer menu button.
3. From the home screen, select the Tools Menu softkey along the right side of the display.
4. Select the System Settings tab along the top of the display and select the Rate Sensor Setup button.
5. Enter a value of 10 [38] for the meter cal.
6. Select the Totals softkey, then the Lifetime Totals tab.
7. Reset the amount applied counter.
8. Toggle the master switch and all boom sections to the off positions.
9. Remove a section hose and place it into a calibrated 5 gallon [19 L] container.
10. Toggle the master switch and the boom switch corresponding to the hose that was placed in the container.
11. Pump exactly 10 gallons [38 L] of water to fill the container twice.
12. Check the total volume registered on the Lifetime Totals tab. The reading displayed is the new meter cal value. This value should be within $\pm 3\%$ of the calibration number stamped on the tag of the flow meter.
13. Repeat this procedure several times to confirm accuracy. Always “zero out” the total volume display before retesting.

NOTE: For increased precision, set meter cal to 100 [378] and pump 100 gallons [378 L] of water.

14. To verify the flow meter calibration, the fill applicator tank with a predetermined amount of measured liquid (i.e. 250 gallons [946.4 L]).

NOTE: Do not rely on graduation marks molded into the applicator tank.

15. Empty the applicator tank under normal operating conditions.
If the total volume displayed is different from the predetermined amount of measured liquid by more than $\pm 3\%$, complete the following calculation:

$$CMC = \frac{MC \times V_M}{V_A}$$

Where CMC = the Corrected Meter Cal, MC = the Meter Cal used to apply the known volume, and VM = the Volume measured by the Lifetime Totals tab, and VA = the predetermined volume applied.

FOR EXAMPLE:

The UT displays a Total Volume of 260 [984] when a Meter Cal of 720 [190] was used to apply a measured volume of 250 gallons [946 L]. Therefore:

English	Metric
$CMC = \frac{720 \times 260}{250} = 749$	$CMC = \frac{[190] \times [984]}{[946]} = [198]$

the Corrected Meter Cal is 749 [198]

16. Return to the Rate Sensor Setup menu and enter a value of 749 [198] for the meter cal.

POWER AND RCM - SPRAYER ECU HARNESS MAINTENANCE

1. Disconnect the RCM - Sprayer ECU harness connector and inspect for signs of moisture or corrosion.
2. If moisture or corrosion is detected, use DeoxIT D5, brushes, and compressed air to clean and dry the connector.
3. When clean, apply a coating of Corrosion X HD to the connector mating surfaces and contacts.
4. Reattach the connectors.

BOOM HARNESS CONNECTOR MAINTENANCE

Prior to connecting the Hawkeye® 2 boom cable to the Hawkeye® 2 Nozzle Control Valves (NCV), perform the following steps to all 8-pin NCV connectors and 19-pin circular connectors between the boom cables and RCM - Sprayer ECU cable connections to ensure high quality connections:

1. Verify the NCV connectors and the accompanying boom cable connectors are free of moisture, contamination, or oxidation. Oxidation will appear as a dry, white coating on the contacts. If any connectors show signs of moisture, contamination, or oxidation, perform Step 2 - Step 6. If this is a new installation, skip to Step 7. All components listed below can be ordered in the Hawkeye® 2 NCV Connection Maintenance Kit (P/N 117-0171-692).
2. Spray the connection with a deoxidizing agent such as the recommended DeoxIT D5 (P/N 222-4001-006).

FIGURE 1. DeoxIT D5 Recommended



3. Clean contacts with a small wire brush (P/N 321-0000-477).

FIGURE 2. Cleaning Contacts



4. Spray the contacts again with the deoxidizing agent. This will rinse out debris.
5. Remove all residue of deoxidizing agent from the connection. Not removing deoxidizing agent can damage the connector seal.
6. Dry out the connection with dry, compressed air. Dust Off Electronics Duster (P/N 222-4001-007) is recommended however, if unavailable, alternate compressed air sources can be used. If using compressed air from a large volume air compressor, be sure the lines are free of moisture.

FIGURE 3. Compressed Air Used to Dry Connector



-
7. If not already applied, apply a single, short burst of corrosion inhibitor such as CorrosionX HD (P/N 222-0000-020) to the NCV connection. Be sure the corrosion inhibitor has coated the NCV contacts and recessed portions of the connector.

NOTE: To determine whether corrosion inhibitor has been applied, inspect for a thick liquid in the bottom of the connector as shown in the image below.

CorrosionX may also be purchased from the manufacturer website:

<https://www.corrosionx.com/products/corrosionx-heavy-duty>.

FIGURE 4. Applying Corrosion Inhibitor

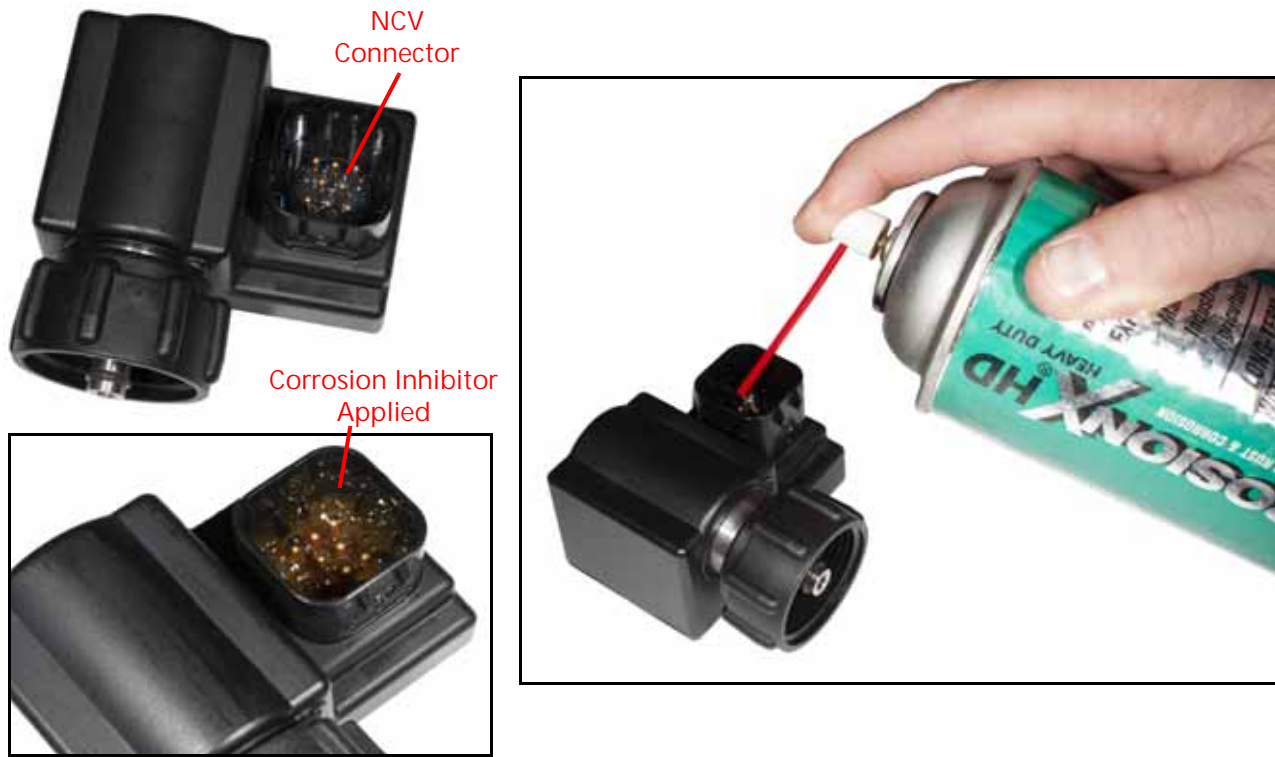

SYSTEM STORAGE AND START-UP CHECKLIST

This section provides procedures to maintain the system. There are checks to perform before storing the equipment and also starting the equipment after long periods without use.

PRESEASON CLEANING AND FLUSHING

The system requires a few steps in addition to your sprayer manufacturer's recommended preseason maintenance and inspection. To prepare the system:

1. Remove and clean all of the product strainers.
2. Replace the cleaned and dried strainers.
3. Fill the product tank with at least 200 gallons [757 L] of clean water.
4. If the boom tubes have a flush valve at the end, open the flush valves and flush the boom tubes with 100 gallons of clean water.
5. Close the flush valves.
6. Remove all of the spray tips or turn the nozzle bodies to an open position (no tips) and flush the booms with the remaining water.

START-UP INSPECTION

Follow the inspection instructions in the vehicle specific installation manual. Perform these steps with the key on without the engine running.

1. Verify that 80 mesh or finer screens are installed upstream of the Hawkeye® 2 NCVs (nozzle control valves).
2. Flush the boom plumbing and tank before running liquid through the Hawkeye® 2 NCVs.
3. Ensure the Hawkeye® 2 NCVs are recognized by the RCM - Sprayer ECU.
If not, repeat the Calibration Wizard. If the RCM - Sprayer ECU is not present on the UT screen, check the vehicle specific Hawkeye® 2 installation manual to verify the RCM - Sprayer ECU cable harness and vehicle power cable harnesses are installed correctly.
4. Ensure that the boom and flow meter information have been properly entered into the equipment settings.
5. Ensure the pressure sensor(s) are configured properly.
 - a. Verify the correct sensor value is entered.
 - b. Relieve trapped pressure in the boom.
6. Ensure the Min and Max PWM have been entered to match the specific value for the application system.

NOTE: Leaving the min at 0 may cause the control valve to respond slowly while the system builds pressure. If the max is left at 100, the control valve may reduce pressure slowly.

7. Verify that the boom configuration has been imported into the machine settings. Failure to do this will cause the boom sections to not be recognized in a job. Virtual sections should show up in boom settings. If properly

completed, the ISO icon at the top right of the screen will be green. Hawkeye® 2 NCVs must be properly indexed for this to work.

8. Ensure there are no active DTCs. Review the *Diagnostics* section on page 51 for assistance with the DTC status indicator if necessary.

NOTE: If there is water in the tank, the following steps may be performed with the engine running and the product pump enabled. Do not run the pump for an extended period of time with no liquid in the tank as this may damage the pump.

If the product pump is not enabled, the system will encounter a pump pressure error.

9. Enter a test speed in the UT mode. The boom section display on the Home page should respond with the corresponding section icons in the UT window.
 - No triangle indicates that the section is off
 - an empty triangle indicates the section is active but is being controlled by automatic section control.
 - A triangle that is filled in blue indicates the section is spraying.

NOTE: The NCVs will emit an audible clicking noise while operating properly.

10. Start a job. Ensure that all necessary widgets are available to the operator to allow proper machine operation. Make a copy for the complete widget setup for the operator to modify.
11. In job view mode, enter a test speed. Verify that the section control is off. The boom section display on the Home page should respond with the corresponding section icons in the UT window.
 - No triangle means the boom is off.
 - An empty triangle indicates the boom is active but is being controlled by automatic section control.
 - A triangle filled in blue means the boom should be spraying. Expect a pump pressure error since the pump is not running. If the booms do not respond correctly, delete and import the boom settings.
12. Once the system is functioning properly, fill the tank with water and complete the functional inspection.

FUNCTIONAL INSPECTION

Refer to the following sections for assistance with validating that the Hawkeye® 2 system has been installed properly:

NOZZLE CONTROL VALVE FUNCTION

To verify that the Hawkeye® 2 system is functioning properly after installation:

1. Flush the main product tank and boom plumbing with clean water, and verify the tank contains at least 100 gallons [379 L] of clean water.
2. Park the equipment in an area with enough space to unfold the booms and allows for visual inspection of the spray pattern from a moderate distance (e.g. 20 ft [6.1 m]).
3. Set the Hawkeye® 2 system to manual mode, and set both the pump PWM and NCV PWM to 50%. Refer to the *(5) Manual Control* section on page 54 for assistance with adjusting the PWM percent values in the manual control mode.

4. Toggle all section switches and the master switch.

	<p data-bbox="808 226 1123 277">WARNING</p> <p data-bbox="685 298 1214 483">Equipment will begin spraying. Avoid inhaling spray particulate and avoid direct contact with any agricultural chemicals. Seek immediate medical attention if symptoms of illness occur during, or soon after, use of agricultural chemicals, products, or equipment.</p>
---	--

5. While maintaining a safe distance away from any spray drift, visually check that all nozzle control valves are pulsing with a uniform pattern. Adjacent nozzle control valves should alternate pulsing. If adjacent spray tips are pulsing at the same time, refer to Chapter 9, *Troubleshooting*, for additional assistance.
6. On the UT, set NCV PWM to 0% to close the nozzle control valves.
7. Visually check that none of the nozzles are spraying or dripping. Refer to *Testing for Leaks* section on page 125 for additional assistance and troubleshooting if leaks are observed.

TURN COMPENSATION FEATURE INSPECTION

To verify the Turn Compensation feature is enabled and operating as anticipated, the user can complete a field test or a stationary simulated test.

NOTE: Complete the procedure outlined in the *Nozzle Control Valve Function* section on page 132 to validate the nozzle control valve function prior to performing the following procedure.

If the Hawkeye® 2 system came installed on the equipment from the equipment manufacturer, or if a sparge pressure transducer is installed with the Hawkeye® 2 control system, check the transducer specifications and refer to the *Pressure Setup* section on page 35 for additional information.

To conduct a field test:

1. Move the implement to an open area where the equipment may be turned.
2. Verify that the turn compensation feature is enabled.
3. Set the system to automatic mode and toggle the section and master switches to the on positions. Refer to Chapter 6, *Operation*, for additional assistance with operation of the nozzle control system.
4. While driving at a speed between 5 and 10 mph [8 and 16 kph] and maintaining a safe working distance, observe the inner-most and outer-most spray tips while the implement is turning sharply.

NOTE: The NCV PWM percent value may also be used to monitor the operation of nozzle control valves across the spray boom. Refer to , *NCV Diagnostics*, for additional assistance with on-screen nozzle control valve diagnostics.

5. While turning, the nozzle control valves toward the outside of the corner should begin to output a higher flow rate (higher PWM percent), while valves toward the inside of the corner should begin to output a reduced flow rate (lower PWM percent) or may shut off. The difference between inner and outer flow rates will vary depending on machine speed, turn rate, and implement width.
6. If the operator is able to observe a difference in the spray pulsing, a difference in high, average, and low values on the NCV performance indicator, or the on-screen PWM percent located in the NCV diagnostics screens, the turn compensation feature is working correctly. If there is no difference between the PWM percent values across the implement width, recalibrate the turn compensation feature and repeat this test.

To conduct a stationary simulated test:

1. Enter a simulated test speed value between 5 and 10 mph [8 and 16 kph].

NOTE: Review the *Test Speed and Turn Compensation* section on page 26 for additional information on the Test Speed feature.

2. Verify that the turn compensation test feature is enabled and set to 2-3 degrees per second, left or right.
3. Conduct the speed test and observe the NCV duty cycles as done in step 5 and step 6 of the field test procedure.

NOTE: Refer to "To conduct a field test:" on page 133 for the field test procedure.

WINTERIZING AND STORING THE SYSTEM

Refer to the sprayer manufacturer winterizing and storing procedure for information on preparing equipment for storage. Do not rely on blow-out systems to remove all the water and/or chemicals from the system. If water, or other fluids, are trapped in the system components could freeze and cause severe damage. System components are compatible with most types of automotive, RV, and marine antifreeze solutions.

WIRELESS SECTION CONTROL REMOTE OPERATION

Refer to the Section Control Remote 2.0 Operation Guide (P/N 016-0171-685) for assistance with using the Section Control Remote 2.0 (P/N 063-0174-064).

To enable communication with the RCM-S ECU:

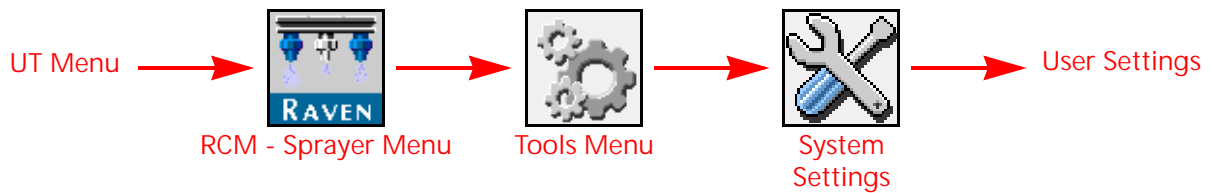

1. Open the UT Menu and select the RCM - Sprayer Menu button.
2. Select the Tools Menu softkey along the right side of the display.
3. Select the System Settings tab along the top of the display.
4. Use the Wireless Control Mode drop-down and select the Section or NCV option.

FIGURE 1. Enable Wireless

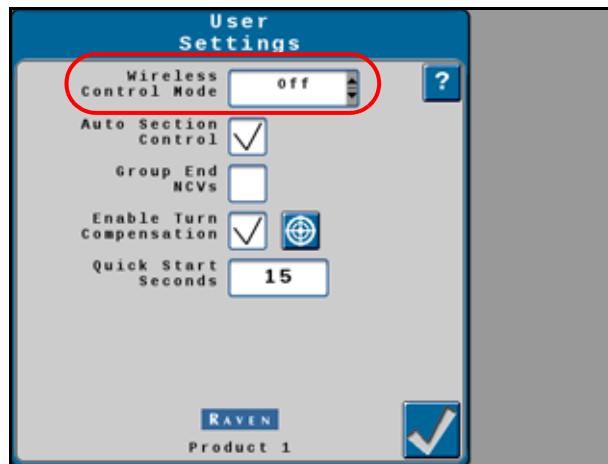

5. Take note of the Wireless ID and passcode on the prompt displayed on the UT. This information will be necessary to connect to the RCM - Sprayer ECU.

FIGURE 2. Wireless Connection Confirmation



IMPORTANT: Do not attempt to connect the remote and RCM - Sprayer devices yet.

OUTSIDE OF THE MACHINE CAB

1. Exit the cab and go to the back of the machine until you have a clear view of the RCM - Sprayer ECU mounting location.

NOTE: The RCM - Sprayer may be mounted within an enclosure and not be directly visible on some OEM installations.

2. Enter the passcode. The passcode should only be required the first time that the section control remote is paired with the RCM - Sprayer ECU.
3. Once the remote is connected to the RCM - Sprayer, the operator may:
 - Toggle the product pump on and off.
 - Toggle boom sections and NCVs on and off as needed using the ON and OFF buttons, Left/Right Indexing Arrows.
 - Sections and NCVs will turn on as the boom is mapped for conventional or bypass section control. To take control of boom sections, use the off and on buttons.

Select the desired RCM - Sprayer ECU Wireless ID and enter the passcode.

NOTE: The wireless ID and passcode are displayed on the UT when the Section or NCV Wireless Control modes are selected. If the remote and RCM - Sprayer ECU have been connected previously, the remote will automatically connect to the RCM - Sprayer ECU when both are turned on and the desired wireless control mode is selected.

LIMITED WARRANTY

WHAT DOES THIS WARRANTY COVER?

This warranty covers all defects in workmanship or materials in your Raven Applied Technology Division product under normal use, maintenance, and service when used for intended purpose.

HOW LONG IS THE COVERAGE PERIOD?

Raven Applied Technology products are covered by this warranty for 12 months from the date of retail sale. In no case will the Limited Warranty period exceed 24 months from the date the product was issued by Raven Industries Applied Technology Division. This warranty coverage applies only to the original owner and is non-transferable.

HOW CAN I GET SERVICE?

Bring the defective part and proof of purchase to your Raven dealer. If the dealer approves the warranty claim, the dealer will process the claim and send it to Raven Industries for final approval. The freight cost to Raven Industries will be the customer's responsibility. The Return Materials Authorization (RMA) number must appear on the box and all documentation (including proof of purchase) must be included inside the box to be sent to Raven Industries.

WHAT WILL RAVEN INDUSTRIES DO?

Upon confirmation of the warranty claim, Raven Industries will (at our discretion) repair or replace the defective product and pay for the standard return freight, regardless of the inbound shipping method. Expedited freight is available at the customer's expense.

WHAT IS NOT COVERED BY THIS WARRANTY?

Raven Industries will not assume any expense or liability for repairs made outside our facilities without written consent. Raven Industries is not responsible for damage to any associated equipment or products and will not be liable for loss of profit, labor, or other damages. The obligation of this warranty is in lieu of all other warranties, expressed or implied, and no person or organization is authorized to assume any liability for Raven Industries.

Damages caused by normal wear and tear, misuse, abuse, neglect, accident, or improper installation and maintenance are not covered by this warranty.

EXTENDED WARRANTY

WHAT DOES THIS WARRANTY COVER?

This warranty covers all defects in workmanship or materials in your Raven Applied Technology Division product under normal use, maintenance, and service when used for intended purpose.

DO I NEED TO REGISTER MY PRODUCT TO QUALIFY FOR THE EXTENDED WARRANTY?

Yes. Products/systems must be registered within 30 days of retail sale to receive coverage under the Extended Warranty. If the component does not have a serial tag, the kit it came in must be registered instead.

WHERE CAN I REGISTER MY PRODUCT FOR THE EXTENDED WARRANTY?

To register, go online to www.ravenhelp.com and select Product Registration.

HOW LONG IS THE EXTENDED WARRANTY COVERAGE PERIOD?

Raven Applied Technology products that have been registered online are covered for an additional 12 months beyond the Limited Warranty for a total coverage period of 24 months from the date of retail sale. In no case will the Extended Warranty period exceed 36 months from the date the product was issued by Raven Industries Applied Technology division. This Extended Warranty coverage applies only to the original owner and is non-transferable.

HOW CAN I GET SERVICE?

Bring the defective part and proof of purchase to your Raven dealer. If the dealer approves the warranty claim, the dealer will process the claim and send it to Raven Industries for final approval. The freight cost to Raven Industries will be the customer's responsibility. The Return Materials Authorization (RMA) number must appear on the box and all documentation (including proof of purchase) must be included inside the box to be sent to Raven Industries. In addition, the words "Extended Warranty" must appear on the box and all documentation if the failure is between 12 and 24 months from the retail sale.

WHAT WILL RAVEN INDUSTRIES DO?

Upon confirmation of the product's registration for the Extended Warranty and the claim itself, Raven Industries will (at our discretion) repair or replace the defective product and pay for the standard return freight, regardless of the inbound shipping method. Expedited freight is available at the customer's expense.

WHAT IS NOT COVERED BY THE EXTENDED WARRANTY?

Raven Industries will not assume any expense or liability for repairs made outside our facilities without written consent. Raven Industries is not responsible for damage to any associated equipment or products and will not be liable for loss of profit, labor, or other damages. Cables, hoses, software enhancements, and remanufactured items are not covered by this Extended Warranty. The obligation of this warranty is in lieu of all other warranties, expressed or implied, and no person or organization is authorized to assume any liability for Raven Industries.

Damages caused by normal wear and tear, misuse, abuse, neglect, accident, or improper installation and maintenance are not covered by this warranty.